

P/N: 7239862
(Rev. H 1/17/05)

SHIPMENT INSPECTION

Thoroughly check the commercial system for possible shipping damage and/or parts loss. Also inspect and note any damage to shipping cartons, crating, etc. If damage is present, notify the transportation company. The manufacturer is not responsible for damage or parts loss in shipment.

Note: Do not mistakenly discard small parts bags when unpacking the system.

All softener* models include; (1) resin tank, (2) brine tank, (3) controller, (4) and a parts box. Another kit includes the aspirator and drain flow control assemblies. The mineral bed consists of one cubic foot bags of water softening resin, and 50 pound bags of various grades of gravel. Refer to the following chart. **Filters** do not** include brine tank or aspirator assemblies.

Note: This manual includes all duplex, triplex, quadplex softeners and filters also.

***Duplex** softeners include 2 resin tanks and 1 brine tank, controller, parts box, aspirator and drain flow control assemblies, and *double* amounts of resin and gravel shown in the table below. **Triplex** softeners include 3 resin tanks and 2 brine tanks, controller, parts box, aspirator and drain flow control assemblies, and *triple* amounts of resin and gravel shown in the table below. **Quadplex** softeners include 4 resin tanks and 2 brine tanks, controller, parts box, aspirator and drain flow control assemblies, and *quadruple* amounts of resin and gravel shown in the table below.

****Duplex** filters include 2 resin tanks, controller, parts box, drain flow control assemblies, and *double* amounts of media. **Triplex** filters include 3 resin tanks, controller, parts box, drain flow control assemblies, and *triple* amounts of media. **Quadplex** filters include 4 resin tanks, controller, parts box, drain flow control assemblies, and *quadruple* amounts of media.

WATER SOFTENER MODEL ➡		102	132	162	192	252	322
1 CU. FT. BAGS OF RESIN		3	4	5	6	8	10
BAGS OF GRAVEL (LBS)	fine	1 (50)	1 (50)	1 (50)	2 (50)	2 (50)	2 (50)
	medium	1 (50)	1 (50)	1 (50)	2 (50)	2 (50)	2 (50)

FILTER MODEL ➡ ➡	CARBON		GREENSAND		MULTI--MEDIA	
	172C	242C	172G	242G	172M	242M
MINERAL (CU FT)	4	10	3	6	–	–
OTHER MINERAL (LBS)	Anthracite	–	78*	156	156	312
	Garnet	–	50	150	50	150
BAGS OF GRAVEL (LBS)	2 (50)	3 (50)	2 (50)	3 (50)	2 (50)	3 (50)
FILTER SAND (LBS)	–	–	–	–	100	250

*partial bag

TABLE OF CONTENTS

Shipment Inspection	2
Specifications / Dimensions	4 – 5
Planning Installation	6
Resin Loading and Assembly	7–11
Bottom Distributor Riser Pipe Length	7
Aspirator Location, Upflow vs Downflow Regeneration	8
Table , Nozzle / Venturi / Flow Controls	10
Installation Steps	12 – 14
Demand Controller <i>Programming at Startup</i>	15 – 17
Table , Controller Setup Information	18
Demand Controller, <i>Resetting Time / Changing Settings / Features and Options</i>	19 – 21
FCC Information	21
External Solenoid During Regeneration	22
Operation, Valve Cycle Sequence / Water Flow Through Conditioner	23 – 32
Maintenance	33 – 41
Refilling Salt Tank / Salt Bridge / Cleaning Nozzle and Venturi	33
Relieving Water Pressure / Suggested Periodic Maintenance	34
Special Disassembly, Assembly Instructions / Aligning Valve with Drive Mechanism	35 – 36
Troubleshooting	38 – 40
Visual and Initial Checks / Automatic Electronic Diagnostic	38 – 39
Manual Electronic Diagnostic	39
Manual Advance Regeneration Check	40
Repair Parts	42 – 47

SAFETY GUIDES

Follow the installation instructions carefully. Failure to install the commercial system properly voids the warranty.

Before you begin installation, read this entire manual. Then, obtain all the materials and tools you will need to make the installation.

Check local plumbing and electrical codes. The installation must conform to them.

Use only lead-free solder and flux for all sweat-solder connections, as required by state and federal codes.

Do not locate the system where freezing temperatures occur. Do not attempt to treat water over 100°F. **Freezing, or hot water damage voids the warranty.**

Avoid installing in direct sunlight. **Excessive sun heat may cause distortion or other damage to non-metallic parts.**

The system requires a minimum water pressure of 30 psi at the inlet. **MAXIMUM ALLOWABLE Inlet water pressure is 125 psi.** If daytime pressure is over 80 psi, nighttime pressure may exceed the maximum. Use a pressure reducing valve if necessary. (Adding a pressure reducing valve may reduce the flow.)

The system works on 24 volt-60 Hz electrical power only. Be sure to use the included transformer.

This system is not intended to be used for treating water that is microbiologically unsafe or of unknown quality without adequate disinfection before or after the system.

SPECIFICATIONS

	WATER SOFTENER MODEL						FILTER		
	102	132	162	192	252	322	172	242	
GRAINS CAPACITY ① (thousands) @ SALT USAGE (lbs)	54 @ 12 ↓ 99 @ 36	72 @ 16 ↓ 132 @ 48	90 @ 20 ↓ 165 @ 60	108 @ 24 ↓ 198 @ 72	144 @ 32 ↓ 264 @ 96	180 @ 40 ↓ 330 @ 120	N/A	N/A	
AMOUNT OF RESIN ② (cu. ft)	3	4	5	6	8	10	4	10	
SALT STORAGE CAPACITY (lbs)	1000	1000	1000	1500	1500	1500	N/A	N/A	
WATER SUPPLY MAXIMUM "CLEAR WATER IRON" (ppm)	5	5	5	5	5	5	dependent on application		
MAXIMUM DRAIN FLOW RATE (GPM)	7	7	7	12	12	12	15* 24**	30* 50**	
FLOW RATE (GPM) AND PRESSURE (PSI) LOSS (ΔP) ③	WATER PRESSURE LOSS (PSI)								
	10 GPM	1.5 ΔP	2 ΔP	2.5 ΔP	1 ΔP	1 ΔP	1 ΔP		
	20 GPM	3.5 ΔP	4.5 ΔP	5 ΔP	2 ΔP	2.5 ΔP	3 ΔP		
	30 GPM	6 ΔP	7.5 ΔP	9 ΔP	4 ΔP	4.5 ΔP	5 ΔP		
	40 GPM	9 ΔP	11 ΔP	13 ΔP	6.5 ΔP	7 ΔP	7.5 ΔP		
	50 GPM	12.5 ΔP	15.5 ΔP	18 ΔP	9 ΔP	9.5 ΔP	10.5 ΔP		
	60 GPM		20 ΔP	23 ΔP	12 ΔP	12.5 ΔP	14 ΔP		
	70 GPM			29 ΔP	15 ΔP	16 ΔP	18 ΔP		
	80 GPM				19 ΔP	20 ΔP	22 ΔP		
	90 GPM					24 ΔP	26 ΔP		
	100 GPM								
	110 GPM								
120 GPM									
WATER SUPPLY PRESSURE RANGE (psi)	30 ↔ 125								
WATER SUPPLY TEMPERATURE RANGE (°F)	35 ↔ 100								
ELECTRICAL RATING	24V – 60Hz								

① **UPFLOW** regeneration

② synthetic high capacity resin or selected filtering mineral

③ Peak flows for intermittent use only.

* flows for carbon filters

** flows for greensand and multi-media filters

DIMENSIONS

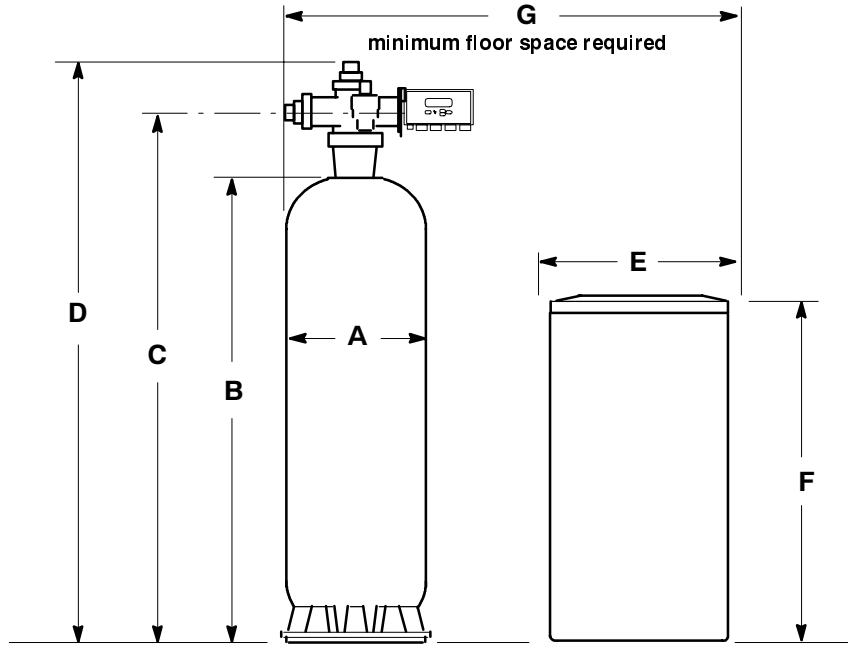

MODEL	A Resin Tank Diameter	B Resin Tank Height	C Inlet – Outlet Height	D Overall Height	E Brine Tank Diameter	F Brine Tank Height	G		INLET – OUTLET Pipe Size	DRAIN Pipe Size (recom. minimum)
							Single	Twin		
102, 132	17"	58"	67"	72.5"	24"	50"	45"	66"	2"	3/4"
162	17"	72"	81"	86.5"	24"	50"	45"	66"	2"	3/4"
192, 252, 322	24"	72"	81"	86.5"	31"	51"	59"	87"	2"	3/4"
172 (Filter)	17"	58"	67"	72.5"	N/A	N/A	17"	50"	2"	1 – 2" ①
242 (Filter)	24"	72"	81"	86.5"	N/A	N/A	24"	54"	2"	1 – 2" ①

① Varies with filter application. Iron filters, requiring higher backwash flows, need 2" drains. Also, drain pipe size should increase with longer drain runs.

PLANS FOR LOCATION AND INSTALLATION OF SYSTEM

WATER SUPPLY: The system requires a potable water supply that will provide a continuous flow to meet regeneration flow specifications. A minimum pressure of 30 psi is required at the conditioner inlet.

BOTH HOT AND COLD WATER CONDITIONING: Connect the system to the water supply pipe, immediately *after* (downstream) the municipal supply water meter or well supply pressure tank. To provide *unconditioned* water to isolated faucets, if desired, run separate pipes from the water supply before the conditioner.

CONDITIONING HOT WATER ONLY: Connect the system to the water supply pipe *before* (upstream) the water heater.

CAUTIONS: (1) **Do not install** the conditioner **after**, or downstream from **the water heater. Hot water will damage** inner parts of the system, and may cause the loss of the water conditioner mineral bed. (2) **To reduce the risk of hot water backing-up**, into the conditioner, piping between the conditioner and water heater should be as long as possible.

DRAIN: A drain is needed nearby the conditioner, capable of carrying away backwash water at the rate of flow listed in the specifications. A floor drain is preferred. Other approved drain points are acceptable, if they do not cause a back-pressure on the conditioner drain pipe or hose. A floor drain is needed for the overflow on the salt tank.

ELECTRICAL: The system works on **24 AC volts only**. A direct plug-in transformer is included to reduce 120 V-60 Hz electrical power to 24 volts. An approved, grounded outlet is needed within 6–1/2' of the conditioner controller. The conditioner includes a 6–1/2' power cable to connect between the transformer and the controller.

SPACE REQUIREMENTS: Be sure to allow sufficient area around the resin and brine tanks for refilling with salt and other service. Minimum floor space and other dimensions are shown on page 5.

MATERIALS YOU MAY NEED

Use the drawing on page 11 as a guide for your installation. The drawing shows typical connection using fittings included with the system, and with optional items available.

■ Be sure to install a 3-valve bypass system. Bypass valves allow you to turn off water to the system, for servicing, while having full-line bypass to the establishment.

■ A **minimum inside diameter** hose or pipe is required for the conditioner valve drain (see page 5). The drain connection at the valve is 2" male pipe thread. Also, on softeners, a length of 5/8" I.D. garden hose is needed for the drain overflow on brine tanks.

■ For in and out pipes to the conditioner, use copper, CPVC plastic, or threaded pipe and fittings. Avoid joining copper and galvanized together as corrosion will occur rapidly. The valve inlet and outlet connections are 2" male pipe thread.

■ **Multiple Unit Installations:** To promote equal water flow, inlet and outlet plumbing configuration to each valve should be as identical as possible (see Figure 1). Use the same fittings and pipe lengths for the connection of each unit, or use a reverse return header.

Figure 1

TYPICAL MULTIPLE UNIT INSTALLATION

Make plumbing to and from both units identical.

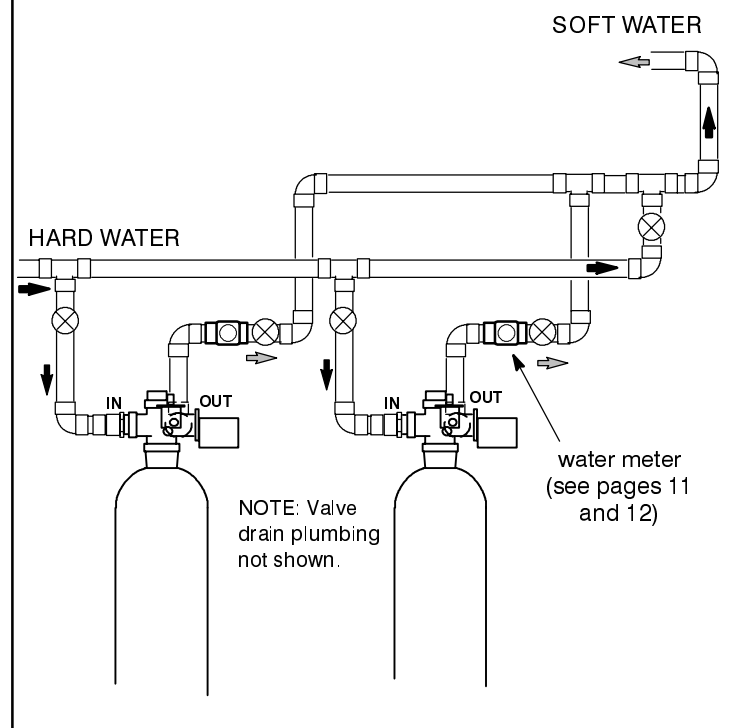

RESIN LOADING AND ASSEMBLY

1. **Move the resin tank into installation location (see page 6).** Set it on a flat, level surface. If a multiple installation, keep tanks separated for ease of service.

Note: Step 2. may be done in an area other than installation location if space is limited.

2. On **all models**, place the *bottom* distributor into the resin tank and center. Check the distributor length as shown in Figure 2, and adjust as needed. *It must extend from 2-5/8" to 3" above the top of the tank.*

Cut square using a hacksaw or pipe cutter. Break the top edge and smooth with sandpaper or a file. Tip the distributor upside-down and tap gently to remove plastic shavings from inside.

3. With a pail or hose, fill the tank with 1 to 2 feet of water. The water acts as a cushion to protect the bottom distributor while filling the tank with gravel, resin or other minerals.

4. Plug the end of the distributor tube with a clean rag, to keep gravel and resin out. Then, place into the tank and center.

5. Using a larger neck funnel, add the specified (see page 2) amount of gravel. **Be sure the distributor remains centered and setting on the tank bottom.**

Note: When coarse, medium and fine gravels are specified, add in that order.

Note for a multi-media filter: Add gravel, garnet, filter sand, and anthracite, in that order.

Note for a greensand filter: Add gravel, garnet, greensand, and anthracite, in that order.

6. Add the specified amount of resin, or filtering minerals, using water sparingly to speed flow through the funnel.

RESIN TANK SIZE	FREEBOARD RANGE*
17 x 58	17 - 21
17 x 72	22 - 26
24 x 72	22 - 26

*Freeboard range, in the preceding chart, is provided only as a guide for maintenance. Freeboard can vary several inches depending on resin bed conditions including...if regenerated or exhausted, total moisture content, settling during shipping and storage, tolerance variables in resin tank size, and amount and type of gravel underbedding.

7. Flush the tank opening with water to clean resin beads from the top of the tank. Then, remove the rag from the distributor tube and apply a light coat of lubricating grease to the top edge of the tube.

8. Finish filling the tank with water, up to the top of the tank.

Important: Be sure to fill with water. This will eliminate air space and prevent excessive air-head pressure when the water conditioner is pressurized.

continued

Figure 2

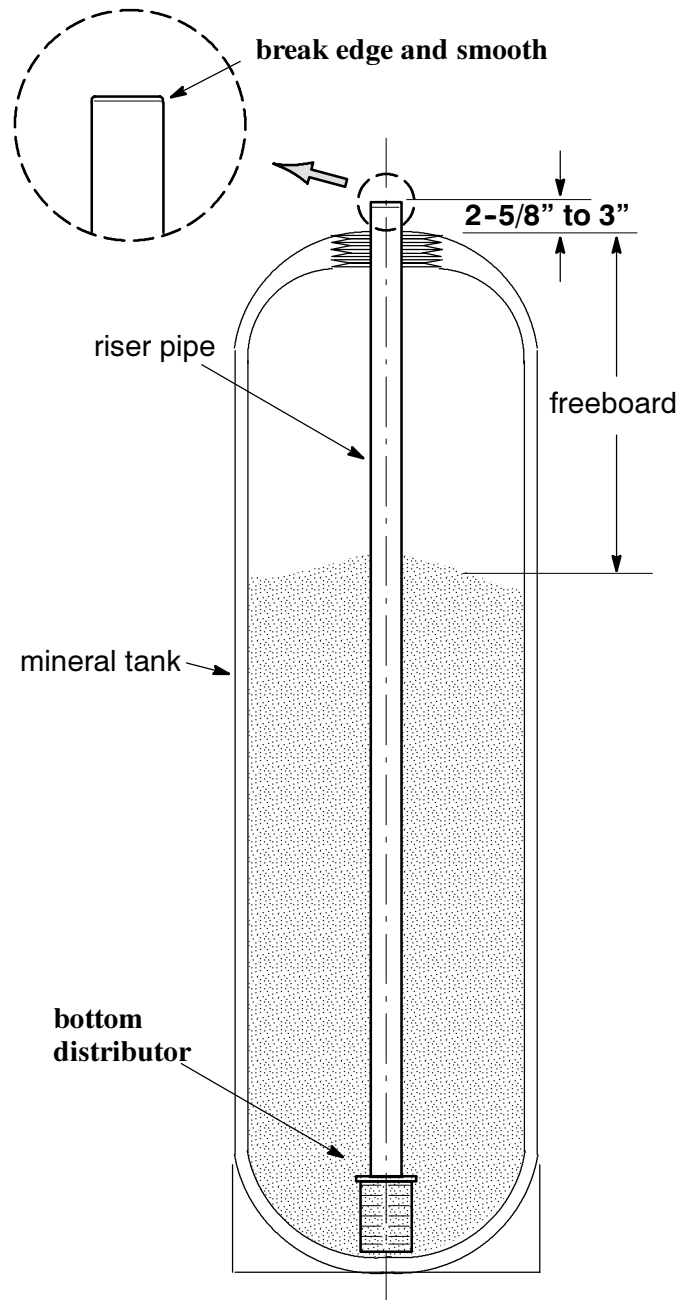

Note: Resin tank height can vary somewhat within manufacturing tolerance. **So to be sure the bottom distributor riser pipe has proper clearance with inside valve porting, check for the correct length as shown above.** Cut the riser if needed to adjust the length. Be sure to remove burrs and sharp edges.

ASSEMBLY

9. From the parts box, obtain the tank adaptor and a 4-1/2" O.D. o-ring seal. Lubricate the o-ring and place in the groove at the bottom of the tank adaptor (Figure 3).

10. Lower the tank adaptor over the bottom distributor and onto the tank. Turn the adaptor clockwise into the tank top opening, *being careful not to cross-thread*. Tighten (use a strap wrench or large pipe wrench) until the adaptor just makes contact with the tank top and no gap is seen. **Do not overtighten and damage the tank threads.**

11. Referring to Figure 3, do the following:

a. Place the screen (except filters) over the top distributor. Then, center the assembly over the bottom distributor riser pipe and push down into the tank adaptor.

b. Place a lubricated 2-3/4" O.D. o-ring onto the top of the riser pipe, and a 4-1/2" O.D. o-ring on the outside, bottom of the support. *With the square key on the support toward the rear*, lower into the tank adaptor, carefully seating into place.

c. Lubricate the 3-1/4" O.D. o-rings and place over the elongated ports on the top of the support.

12. Lower the valve assembly onto the tank adaptor and support (Figures 3 and 4). The valve must be lowered straight down or the o-rings will slip out of place. Install the two large clamps, securing with the two retainers. **Be sure the clamps and retainers are secured in place.**

The aspirator (or aspirator plug for filters) and drain flow control nipple assemblies, needed for your model, are packed in a separate carton. The assemblies contain all of the required parts for upflow regenerated softeners on medium range water supply pressures (refer to the chart on page 10). See step 15 to install.

When installing a softening system on low or high water pressures, and all downflow regeneration applications (specified when sizing and ordering) different nozzle/venturi/pre-nozzle flow plug combinations are needed. The parts required to control brine and rinse rates for your particular application are included in a separate parts bag so you can convert the aspirator (Figure 5).

13. Using 3-1/4" O.D. o-rings, clamps and retainers, install 2" nipples in the inlet and outlet valve ports (figure 4). **Be sure the clamps and retainers are secured in place.**

14. Using 3-1/4" O.D. o-ring, clamps and retainers, install the factory assembled (with flow controls) drain nipple in the valve outlet port (Figure 4 and 5). **Be sure the clamps and retainers are secured in place.**

continued

Figure 3

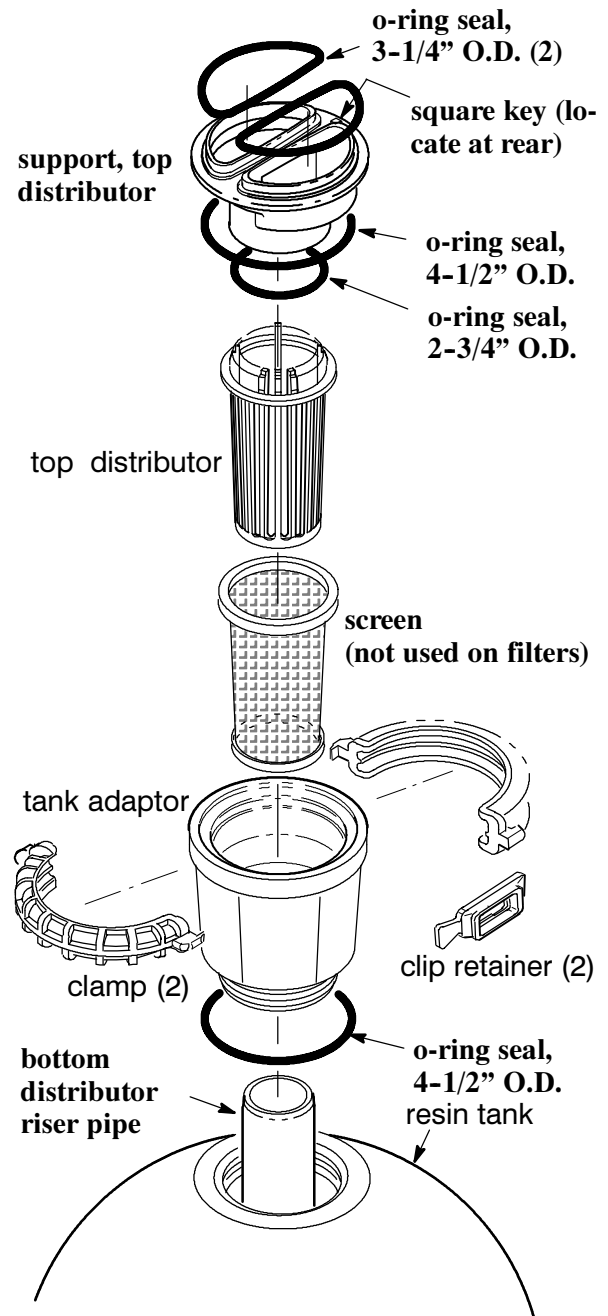

ASSEMBLY

Figure 4

nipple, 2" (assembled with required flow plugs - see pages 41 and 44)

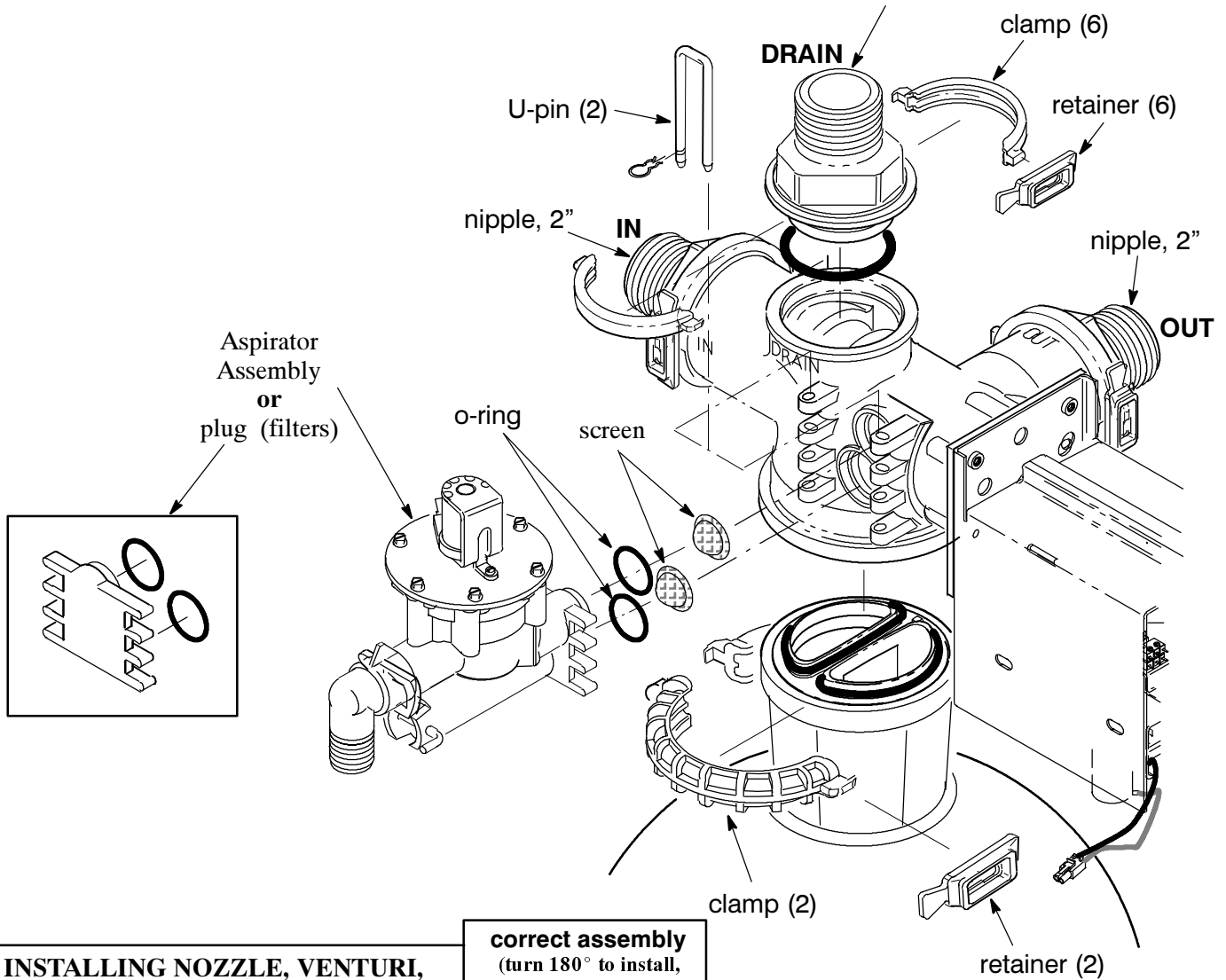

5. INSTALLING NOZZLE, VENTURI, PRE-NOZZLE FLOW PLUG (if required - see chart on page 10)

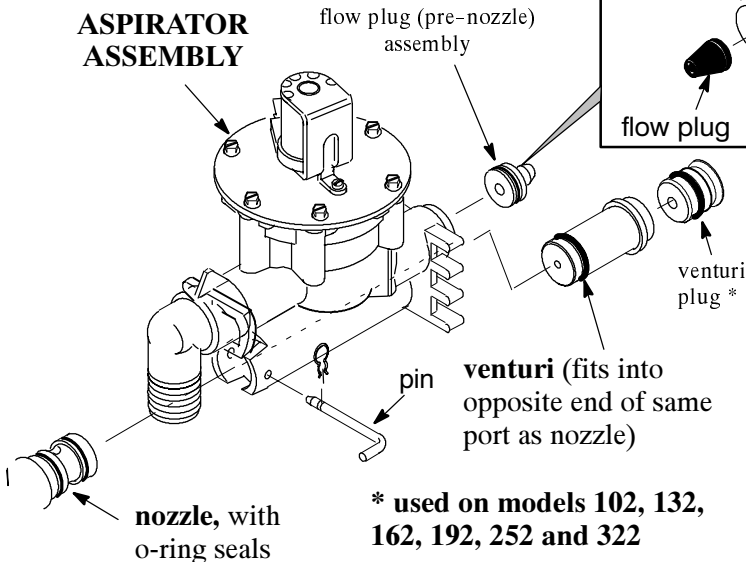

correct assembly
(turn 180° to install, small end of flow plug toward valve)

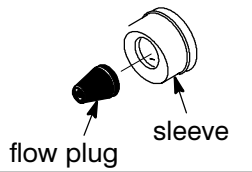

6. ASPIRATOR ASSEMBLY LOCATION DOWNFLOW REGENERATION

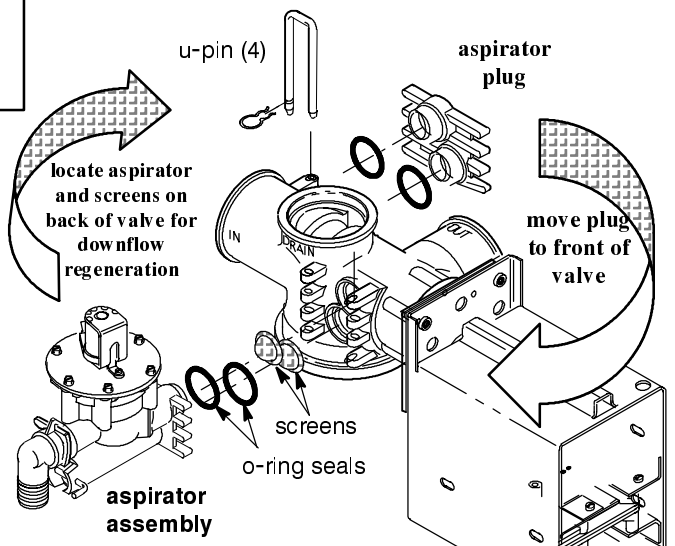

ASSEMBLY

15. Softeners only: The aspirator assembly has all of the required components to control brine and rinse rates for *upflow* regeneration applications at *medium* water pressures (shaded rows in following chart). If these conditions apply to this installation, do step **a** below. Refer to Figures 4 and 5, page 9.

If the system is installed on low or high water pressures, and all downflow regeneration applications, (specified when sizing and ordering) the parts required to control brine and rinse rates for your particular application are included in a separate parts bag so you can convert the aspirator. Do following step **b**.

a. Install the aspirator, as factory assembled, on the front of the valve. Be sure to use screens and o-ring seals. Secure in place with two u-pins.

b. Convert the aspirator assembly following the chart below. Then, for upflow regeneration, install the aspirator using step **a**. For downflow regeneration, do following step **c**.

Notes (see Figure 5): To remove the nozzle and/or venturi, use a common screwdriver in the pry slots provided. – – Be sure to face the small end of the pre-nozzle flow plug toward the 2” valve. – – Be sure to transfer the venturi plug, used on specified models.

c. After converting the aspirator, remove the plug on the backside of the valve and install the aspirator, see Figure 6. Be sure to use screens and o-ring seals. Secure in place with two u-pins. Move the plug to the front of the valve and install using o-rings and u-pins.

16. Filters only: Install the aspirator plug on the front of the valve. Be sure to use the o-ring seals. Secure in place with two u-pins.

model	regeneration water flow	system water pressure (psi)	aspirator assembly parts conversions required	
			nozzle / venturi (pull clip and pin)	pre –nozzle flow plug
102	UPflow	low (30–55)	use as assembled (purple)	remove, not used
		med (40–85)	use as assembled (purple)	use as assembled (blue)
		high (65–125)	change to green	change to light blue
132	DOWNflow	low (30–45)	change to black	remove, not used
		med (35–95)	change to red	remove, not used
		high (60–125)	change to gray	remove, not used
162	DOWNflow	low (30–65)	change to red	install sleeve, with green flow plug
		med (35–80)	use as assembled (gray)	use as assembled (none used)
		high (45–125)	change to red	install sleeve, with orange flow plug
192	UPflow	low (30–55)	change to yellow	use as assembled (none used)
		med (40–125)	change to black	use as assembled (none used)
		high (95–125)	change to red	use as assembled (none used)
252	DOWNflow	low (30–55)	change to yellow	use as assembled (none used)
		med (40–125)	change to black	use as assembled (none used)
		high (95–125)	change to red	use as assembled (none used)
322	DOWNflow	low (30–55)	change to yellow	use as assembled (none used)
		med (40–125)	change to black	use as assembled (none used)
		high (95–125)	change to red	use as assembled (none used)

TYPICAL INSTALLATION PLUMBING (SOLDERED COPPER OR CPVC PLASTIC SHOWN.)

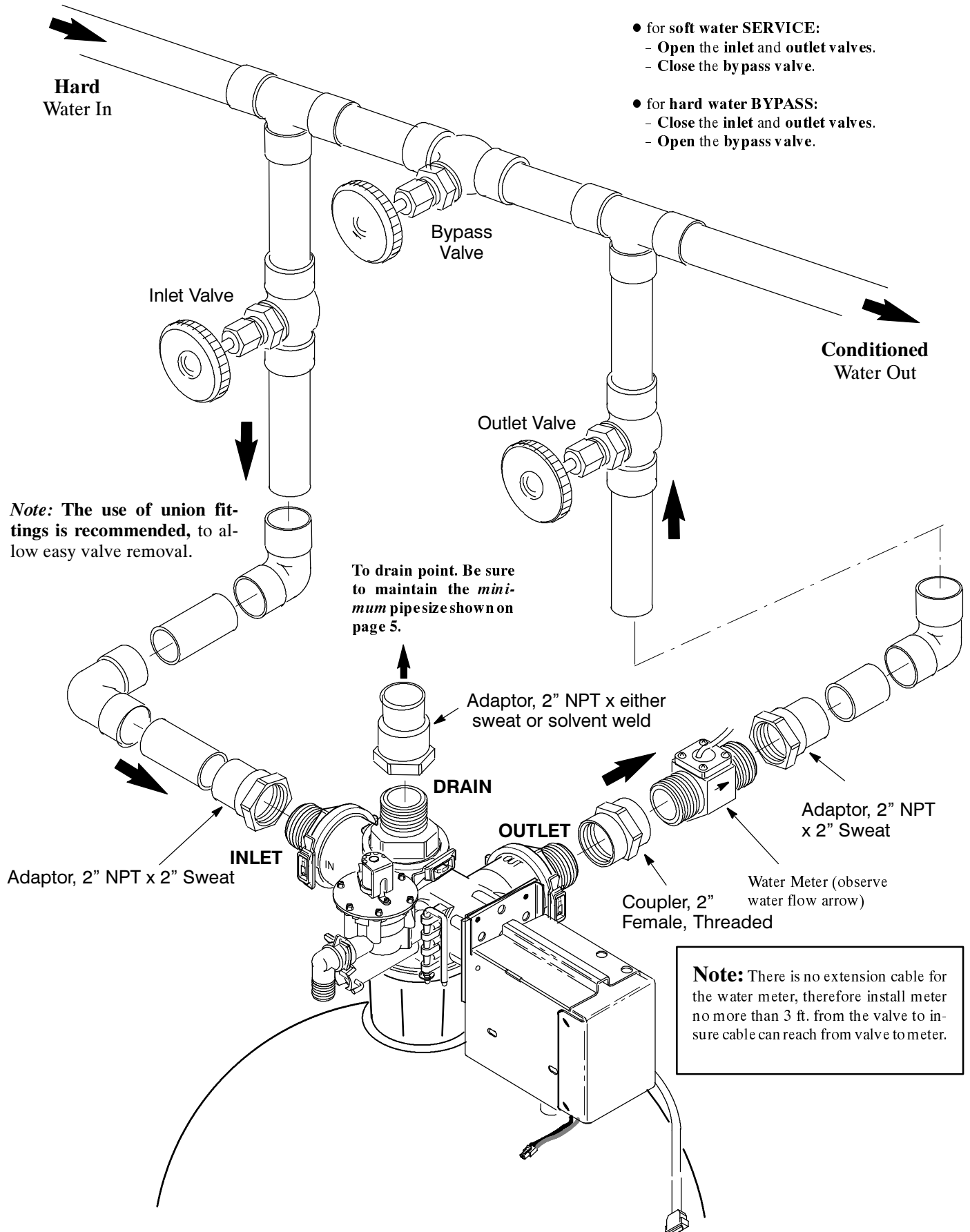

INSTALLATION STEPS

NOTES AND CAUTIONS WHEN MAKING IN, OUT AND DRAIN PLUMBING CONNECTIONS:

- **Be sure to close the main water supply valve to turn off the water.**
- **CAUTION:** When soldering, make sub-assemblies of the inlet, outlet and drain plumbing. Solder the sub-assemblies and allow to cool before turning onto the valve fittings. **Soldering heat will damage the valve adaptor fittings.**

Example: Looking at page 11, make soldered sub-assemblies of the 2" NPT x 2" sweat adaptors and a length of pipe. Allow to cool before turning onto the valve fittings. Then, wrap wet rags around the sub-assemblies when making other solder joints nearby the valve.

- **Install a 3-valve bypass** system as shown on page 11. Bypass valves allow you to direct water through the softener or filter, or to bypass it if needed. For multiple tanks, see a typical installation, Figure 1, page 6.
- **Use union fittings** to enable easy disconnection and maintenance of the valve and resin tank, if needed.
- **Use Teflon tape or pipe joint compound** on all outside pipe threads.
- If needed, **lubricate o-ring seals** with high quality silicone grease.
- **Be sure to plumb so hard water is directed to the valve inlet.**
- **Support all plumbing** in an acceptable manner (pipe hangers, strapping, etc.) to keep the weight off of the valve.

-
1. Referring to the typical installation drawing on page 11, plumb the main **water supply to the valve inlet adaptor** (valve is marked *IN*). Be sure to observe all notes and cautions above.
 2. Run plumbing from the valve outlet (marked *OUT*), back to the main water supply pipe. Be sure to install the water meter **horizontally or vertically downward only** (will not work accurately with flow arrow pointing upward), and to *observe the water flow direction arrow*. For ease of installation, remove meter assembly from housing until all plumbing connections are complete. When reassembling, observe that the directional arrows are properly aligned.
 3. Run a pipe from valve **DRAIN** fitting to the drain point. Be sure the drain pipe is *no less than* the recommended minimum diameter (see page 5) along the entire run. A restriction, causing back-pressure, may prevent proper operation of the conditioner. Observe the following.
 - Be sure the floor drain (or other acceptable drain...observe local codes) is capable of carrying away the backwash flows listed in the specifications.
 - Provide an air-gap between the end of the drain pipe and the drain point. The air-gap prevents a possible siphoning of sewer water if the drain backs up.
 - Keep the drain run as short as possible and with a minimum of elbows, bends, etc. to promote good flow.
 - Easy access to the drain point is desirable to check regeneration cycle flow rates.
 4. Move the brine tank (water softener only) into position nearby the resin tank, setting on a flat, smooth surface. **Do not set on protrusions or uneven surfaces that could cause the tank to puncture or break.** If assembly is needed, place the brine valve (or air check) in the brinewell and put both into the brine tank. Insert brine valve top elbow out the hole in the brine tank sidewall. Install the 3/4" x 1/2" reducer (Figure 7).
 5. **CONNECT BRINE TUBING:** Install the reducer and tubing connector fittings at the brine elbow (Figure 7), and a tubing connector at the brine valve. Connect a length of 1/2" O.D. tubing between the fittings, routing out of the way, and without sharp bends or kinks.

continued

INSTALLATION STEPS

Connect brine tubing – continued

Note: If a multiple tank installation, use the 1/2" nipple and tee fitting to make connections to both valve drain elbows (see below).

6. **BRINE TANK OVERFLOW HOSE:** Install a length of 5/8" I.D. garden hose to the brine tank overflow elbow fitting. Place the outlet of the hose over the floor drain.

Note: This is a gravity drain. **Do not** elevate the hose higher than the elbow fitting in the tank sidewall.

7. **PRESSURE TESTING:** **To prevent excessive air pressure in the conditioner tank, do the following steps in exact order.** Single tank only – Multiple tanks, see note at bottom of page.

Caution: If you did not fill the conditioner tank with water in step 8, page 7, first complete steps 9 through 12. Then, using the Recharge button, and observing the decal on the bottom of the controller, **cycle the valve into backwash (#7) position.** Press the Recharge button once, move the cursor (>) to Recharge Now and press the Menu/Exit (↵) button. Move the cursor (>) to Tank #1 and press Recharge button once to advance to each position, until you reach backwash. Complete the following pressure testing steps.

- Fully open two or more *conditioned* cold water faucets nearby the conditioner.
- Place the plumbing bypass valves in hard water "bypass" position (see page 11). – Close the inlet and outlet valve; open the bypass valve.
- Fully open the *main water supply valve*. Observe steady flow from the opened faucets, with no air bubbles.
- **EXACTLY** as follows, place bypass valves in soft water "service" position.

SLOWLY, open the inlet valve, pausing several times to allow the unit to pressurize slowly. (If you cycled the valve into backwash, water will flow from the drain.) Open the outlet valve and close the bypass valve.

- **After about 3 minutes, open a hot water faucet** for about one minute, or until all air is expelled, then close. (If you cycled the valve into backwash, use the *Recharge* button to return the valve to service.)

Caution, multiple tank systems with blocked pistons to prevent bypass water during regenerations: Never cycle a valve, when pressurized, with the plumbing bypass valves closed. Damage to the valve, drive mechanism, and motor may occur if water, displaced by the blocked valve piston (see pages 25 and 26), can not enter nearby plumbing. **Be sure plumbing valves are open to all tanks before advancing a valve to the next cycle.**

- **Close all cold water faucets** and check your plumbing work for leaks. Repair any leak before continuing.

Figure 7

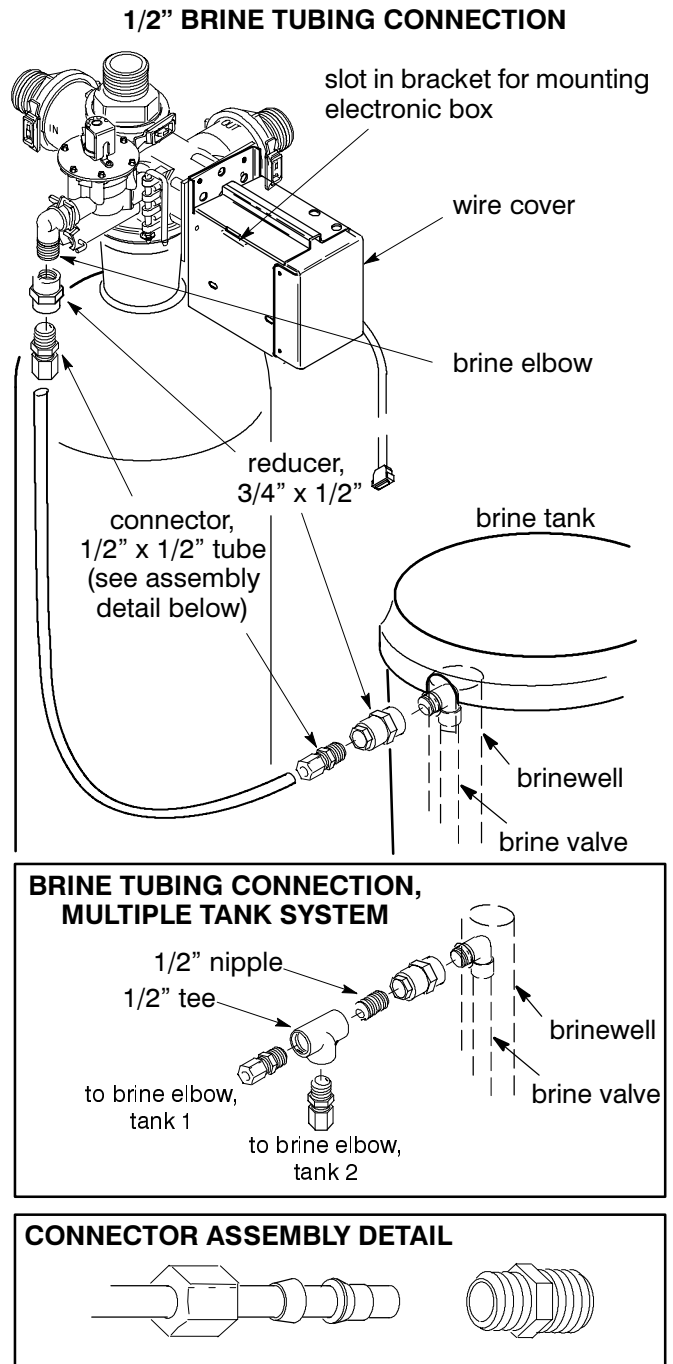

INSTALLATION STEPS

8. **FILL THE BRINE TANK WITH WATER AND SALT:** Add about 1 – 1/2” to 2” of water into the brine tank. Then, fill with **clean** water softener salt. **The recommended *nugget, pellet and coarse solar salts* have less than 1% impurities.** Salt storage capacities are shown in the table on page 4.

9. A soldered copper 3-valve bypass, as shown on page 11, maintains **cold water pipe ground continuity**. If your installation breaks continuity (plastic pipe, dielectric fittings, etc.), provide a jumper wire across the removed section of metal pipe. Securely clamp the wire on both ends, being sure good contact is made between the wire and pipe.

10. **MOUNT THE ELECTRONIC BOX** on the front of the controller (Figure 7) or in a convenient location nearby the conditioner(s), and within reach of water meter and power cord connections.

11. **CONNECT LEADWIRES:** Referring to the diagram below, and to Figure 7 on page 13, connect electrical leadwires as follows.

Note: The transformer must be unplugged before connecting or disconnecting controller cables. If not, it may result in damage to controller circuits.

- power cable to the terminals on the transformer [1]
- controller cable to electronic box [2]

Note for multiple tank installation: Only one transformer is required for multiple units [3].

12. **PLUG TRANSFORMER INTO A 120V – 60Hz ELECTRICAL OUTLET.**

13. **DO THE STARTUP PROGRAMMING:** Upon installation, **all** timer control settings are required. **Follow procedures on pages 15 through 17.**

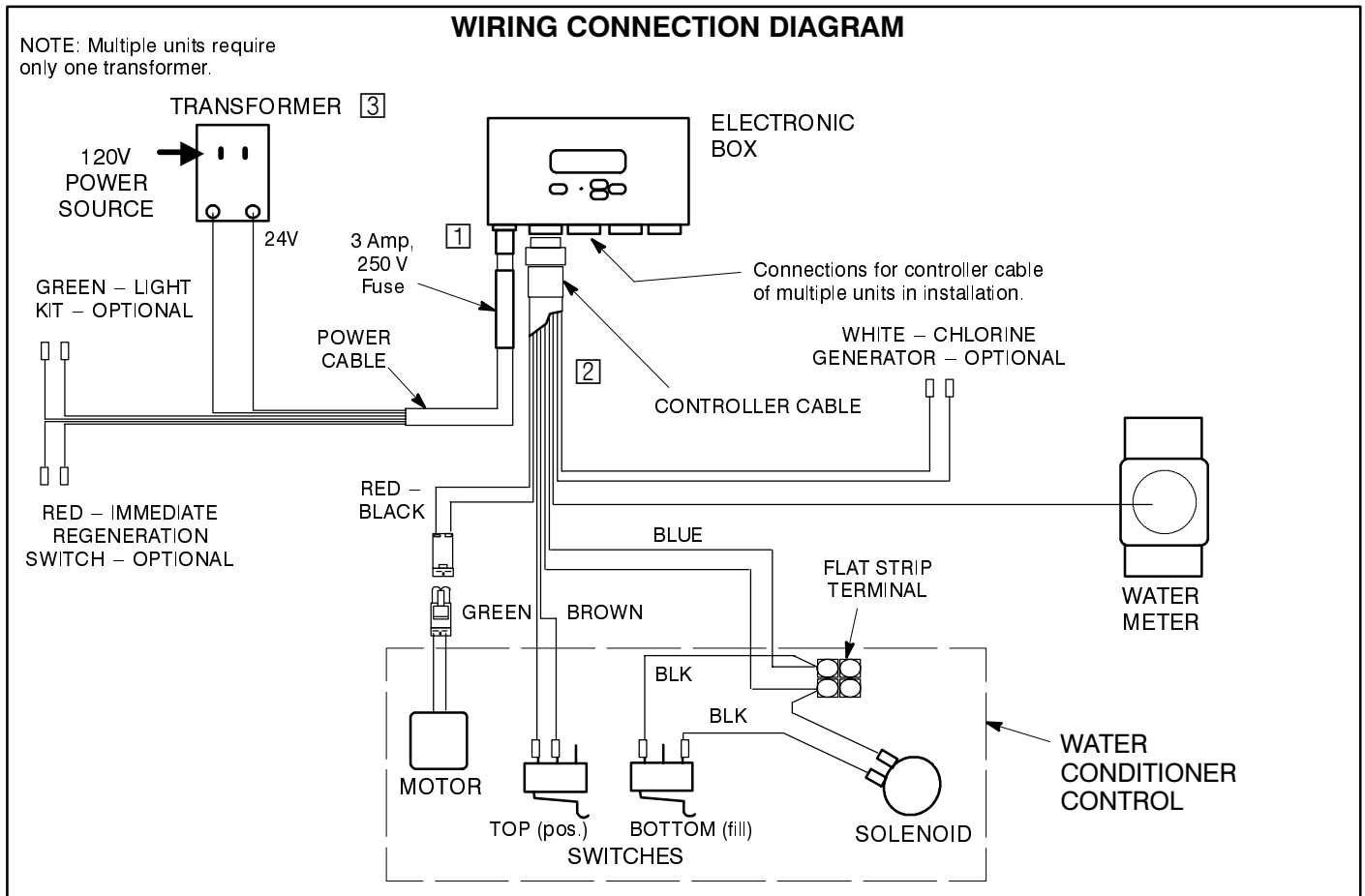

PROGRAMMING THE ELECTRONIC CONTROLLER AT STARTUP

(See page 19 to reset time and other settings, once programmed)

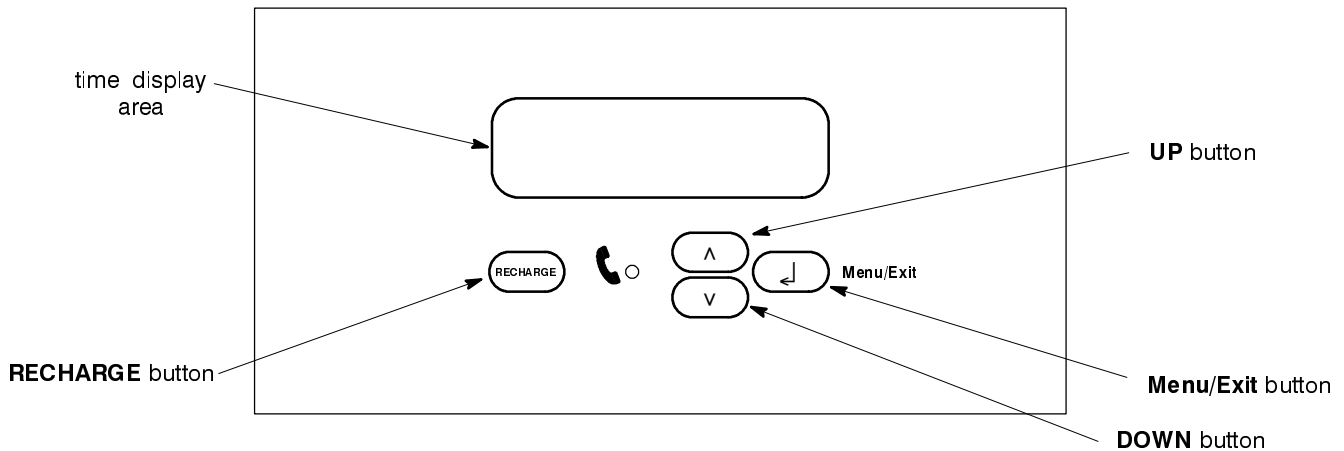

The electronic controller is a menu driven system with a dot matrix display. The Up (↑) and Down (↓) buttons move the cursor (>) up and down the menu choices. The Menu/Exit (↵) button enters the value selected and returns the display back a level. The controller will return to the normal operating screen after 4 minutes if left in a menu and no selection has been made.

● **SOUND “BEEPER”**– A “beeper” sounds while pressing buttons for controller setup. One beep signals a change in the faceplate display. Repeated beeps means the controller will not accept a change from the button you have pressed, telling you to use another button.

When the transformer is first plugged in, a screen is displayed for approximately 8 seconds showing the software version, then the following screens are displayed to program the controller.

1. SET LANGUAGE: Using the up (↑) or down (↓) buttons, move the cursor (>) next to the preferred language. Press the Menu/Exit (↵) button to select and advance to next setting.

```
-----
Version : C2.0
```

2. SET VALVE TYPE: Use the up (↑) or down (↓) buttons to display 2 inch upflow valve or 2 inch downflow valve. When the correct application is shown, press the Menu/Exit (↵) button to select and advance to next setting.

```
> English
  Español
  Français
↑↓ Change                               ↵ Exit
```

3. SET NUMBER OF VALVES: If one softener or filter is installed, set Simplex in the display using the up (↑) or down (↓) buttons, press the Menu/Exit (↵) button to select and advance to next setting. If multiple units are installed, set for Duplex, Triplex or Quadplex as applies for the installation.

```
Set Valve
Type:
Two Inch Upflow
↑↓ Change                               ↵ Next
```

4. SET RECHARGE METHOD (for multiple tank applications only): There are four choices for recharge method. Peak Flow, Alt. Immediate, Parallel Immediate or Parallel Delayed. When Peak Flow (see step 15) is selected, each tank recharges as capacity is used. Alt. Immediate initiates an immediate recharge on a tank as capacity is used. When that tank is finished recharging it is put in standby mode. Parallel Immediate recharges each tank in sequence immediately as capacity is used. Parallel Delayed recharges each tank in sequence at the scheduled recharge time. Using the up (↑) or down (↓) button, select recharge method and press the Menu/Exit (↵) button to select and advance to next setting.

```
Set Number of
Valves:
Quadplex
↑↓ Change                               ↵ Next
```

5. SET SYSTEM TYPE: Using the up (↑) or down (↓) button, select either softener or filter system type and press the Menu/Exit (↵) button to select and advance to next setting. If filter is selected, go to step 19 on page 17, for further settings.

```
Set Recharge
Method:
Parallel Delayed
↑↓ Change                               ↵ Next
```

6. SET RESIN QUANTITY: Using the up (↑) or down (↓) button, select amount of resin, in increments of .5 cubic feet (per tank), that will be used in the system. Press the Menu/Exit (↵) button to select and advance to next setting.

```
Set System
Type:
Softener
↑↓ Change                               ↵ Next
```

```
Set Resin
Qty:
1.5 cu. ft.
↑↓ Change                               ↵ Next
```

continued

PROGRAMMING THE ELECTRONIC CONTROLLER AT STARTUP

7. SET REFILL RATE: Using the up (↑) or down (↓) button, select refill rate to the suggested gallons per minute flow rate from the table on page 18. Press the Menu/Exit (↵) button to select and advance to next setting.

Set Refill Rate: 2.0 GPM ↑↓ Change	↵ Next
---------------------------------------------	--------

8. SET EFFICIENCY MODE: Using the up (↑) or down (↓) button, select Salt Efficient, Boiler Option, Auto Adjusting or Actual Dose. Salt Efficient will obtain a salt efficiency of 4,000 grains or higher. Boiler Option will have 1 ppm soft water bleed or less. Auto Adjusting adjusts itself on 5 operating capacities, based on frequency of regenerations. Actual Dose allows user to set actual salt dose in lbs/cu. ft. If Actual Dose is selected, the controller will continue on to a Set Salt Dose screen. Press the Menu/Exit (↵) button to select and advance to next setting. Note: If Auto Adjusting is chosen, brine times will still need to be selected in step 10.

Set Efficiency Mode: Actual Dose ↑↓ Change	↵ Next
Set Salt Dose: 10 lb per ft3 ↑↓ Change	↵ Next

9. SET FIXED RESERVE: (Simplex or Parallel Delayed Systems only) If a minimum capacity must be available on any given day, use the up (↑) or down (↓) button to select the percentage of operating capacity required. See the chart on page 18 to determine actual capacity available. If Automatic is selected, the fixed reserve percentage varies, based on a weekly average of capacity used. Press the Menu/Exit (↵) button to select and advance to next setting.

Set Fixed Reserve: Automatic ↑↓ Change	↵ Next
-------------------------------------------------	--------

10. SET BRINE TIME: Using the up (↑) or down (↓) button, select brine time to the suggested minutes from the table on page 18. Press the Menu/Exit (↵) button to select and advance to next setting.

Set Brine Time: 180 Minutes ↑↓ Change	↵ Next
------------------------------------------------	--------

11. SET BACKWASH TIME: Using the up (↑) or down (↓) button, select backwash time to the suggested minutes from the table on page 18. Press the Menu/Exit (↵) button to select and advance to next setting.

Set Backwash Time: 15 Minutes ↑↓ Change	↵ Next
--------------------------------------------------	--------

12. SET FAST RINSE TIME: Using the up (↑) or down (↓) button, select fast rinse time to the suggested minutes from the table on page 18. Press the Menu/Exit (↵) button to select and advance to next setting.

Set Fast Rinse Time: 5 Minutes ↑↓ Change	↵ Next
---------------------------------------------------	--------

13. SET SALT MONITOR FEATURE: Using the up (↑) or down (↓) button, display ON or OFF. If ON is selected, you must also enter the diameter of the brine tank. If this is a multiple valve application, and ON is selected, the number of Valves Per Brine Tank must be entered. Press the Menu/Exit (↵) button to select and advance to next setting.

Set Salt Monitor Feature: OFF ↑↓ Change	↵ Next
--------------------------------------------------	--------

14. SET MINIMUM TANKS IN SERVICE (Triplex and Quadplex units only): Using the up (↑) or down (↓) button, display the minimum number of tanks that are needed to be in service at a time. Press the Menu/Exit (↵) button to select and advance to next setting.

Set Minimum Tanks In Service: 3 Tanks ↑↓ Change	↵ Next
----------------------------------------------------------	--------

15. SET PEAK FLOW TRIP POINT: If Peak Flow is selected as method of recharge (step 4), this option is activated. Using the up (↑) or down (↓) button, select the GPM (1.0 minimum to 750 maximum) at which you **temporarily** require another unit to come into service. The unit will return to standby when the GPM falls below the set point after a period of 30 minutes. Press the Menu/Exit (↵) button to select and advance to next setting.

Peak Flow Trippoint: 8.0 GPM ↑↓ Change	↵ Next
-------------------------------------------------	--------

After these initial settings are completed, the monitor will display a screen stating the controller is being reset. The monitor will then show a screen with the current settings before moving to the next screen and required setting.

Softener 2UF Quadplex ----- Version : C2.0

16. SET CLOCK: Using the up (↑) or down (↓) button, set the present time, being sure AM or PM shows, as applicable. By pressing and holding either the up (↑) or down (↓) button, the display will scroll at faster increments. Press the Menu/Exit (↵) button to select and advance to next setting. Note: Clock will need to be reset only if power was out longer than 72 hours.

Set Clock: 12:00PM ↑↓ Change	↵ Exit
----------------------------------------	--------

continued

17. SET HARDNESS: Using the up (↑) or down (↓) button, set the water hardness level, from 1 to 160 grains or 10 to 2740 PPM (parts per million). By pressing and holding either the up (↑) or down (↓) button, the display will scroll at faster increments. Press the Menu/Exit (↵) button to select and advance to next setting.

Set Hardness:	
25 Grains	
↑↓ Change	↵ Exit

18. SET RECHARGE TIME: This screen is active only if a single valve system or Parallel Delayed recharge setting. Using the up (↑) or down (↓) button, set the time when regenerations should start. Press the Menu/Exit (↵) button to select and advance to next setting.

Set Recharge Time:	
2:00 AM	
↑↓ Change	↵ Exit

The monitor returns to the normal operating screen when programming has been completed.

Recharge Tonight At:	12:03 PM
2:00 AM	
	↵ Menu

The installation, and programming steps are complete.

PROGRAMMING THE ELECTRONIC CONTROLLER AT STARTUP - FILTERS

19. SET FILTER CAPACITY: Using the up (↑) or down (↓) button, select OFF, or a pre chosen number of gallons, in 1000 gallon increments, at which you want the filter to backwash. If OFF is selected, the filter will not backwash automatically, and it must be initiated manually. Press the Menu/Exit (↵) button to select and advance to next setting.

Set Filter Capacity:	
1000	
↑↓ Change	↵ Next

20. SET BACKWASH TIME: Using the up (↑) or down (↓) button, select backwash time from 1 minute minimum to 30 minutes maximum. The minimum time for filters is about 20 minutes. Increase the time as needed to thoroughly clean the filter bed. Press the Menu/Exit (↵) button to select and advance to next setting.

Set Backwash Time:	
15 Minutes	
↑↓ Change	↵ Next

21. SET FAST RINSE TIME: Using the up (↑) or down (↓) button, select fast rinse time from 1 minute minimum to 30 minutes maximum. Press the Menu/Exit (↵) button to select and advance to next setting.

Set Fast Rinse Time:	
5 Minutes	
↑↓ Change	↵ Next

22. SET MINIMUM TANKS IN SERVICE (Triplex and Quadplex units only): Using the up (↑) or down (↓) button, display the minimum number of tanks that are needed to be in service at a time. Press the Menu/Exit (↵) button to select and advance to next setting.

Set Minimum Tanks: In Service	
3 Tanks	
↑↓ Change	↵ Next

After these initial settings are completed, the monitor will display a screen stating the controller is being reset. The monitor will then show a screen with the current settings before moving to the next screen and required setting.

Filter	
2UF Quadplex	

Version : C2.0	

23. SET CLOCK: Using the up (↑) or down (↓) button, set the present time, being sure AM or PM shows, as applicable. By pressing and holding either the up (↑) or down (↓) button, the display will scroll at faster increments. Press the Menu/Exit (↵) button to select and advance to next setting. Note: Clock will need to be reset only if power was out longer than 72 hours.

Set Clock:	
12: 00PM	
↑↓ Change	↵ Exit

24. SET RECHARGE TIME: This screen is active only if a single valve system or Parallel Delayed recharge setting. Using the up (↑) or down (↓) button, set the time when regenerations should start. Press the Menu/Exit (↵) button to select and advance to next setting.

Set Recharge Time:	
2:00 AM	
↑↓ Change	↵ Exit

The monitor returns to the normal operating screen when programming has been completed.

Water Flow Rate:	12:03 PM
2.0 GPM	
	↵ Menu

The installation, and programming steps are complete.

WATER SOFTENER CONTROLLER SET-UP INFORMATION

MODEL	Resin Quantity (cu ft)	Fill Rate (gpm)	Salt Dosage (lbs/cu ft resin)	Grains Capacity (upflow)	Brining Minutes (upflow)	Grains Capacity (downflow)	Brining Minutes (downflow)	Backwash Minutes	Fast Rinse Minutes
102	3	1.0	4, Auto Adj. or Salt Eff.	54,000	115	50,000	60	12	5
			6	72,000	110	68,000			
			8	84,000	105				
			10	93,000	100	75,000			
			12	99,000	95				
132	4	1.0	4, Auto Adj. or Salt Eff.	72,000	150	67,000	70	12	5
			6	96,000	145	91,000			
			8	112,000	135				
			10	124,000	130	100,000			
			12	132,000	125				
162	5	1.0	4, Auto Adj. or Salt Eff.	90,000	180	84,000	60	12	5
			6	120,000	175	114,000			
			8	140,000	170				
			10	155,000	160	125,000			
			12	165,000	150				
192	6	2.0	4, Auto Adj. or Salt Eff.	108,000	110	100,000	60	14	10
			6	144,000	105	137,000			
			8	168,000	100				
			10	186,000	95	150,000			
			12	198,000	80				
252	8	2.0	4, Auto Adj. or Salt Eff.	144,000	145	134,000	70	14	10
			6	192,000	140	182,000			
			8	224,000	130				
			10	248,000	125	200,000			
			12	264,000	120				
322	10	2.0	4, Auto Adj. or Salt Eff.	180,000	180	168,000	80	14	10
			6	240,000	175	228,000			
			8	280,000	170				
			10	310,000	160	250,000			
			12	330,000	150				

ELECTRONIC CONTROLLER, RESETTING CONTROLLER, FEATURES AND OPTIONS

RESETTING TIME

To set the time if incorrect, or if the display is flashing after a power outage longer than 72 hours, reset as follows. When power is lost, all other settings are maintained by the computer and do not require setting (see Program Memory).

1. Press the Menu/Exit button (↵) to enter the Primary Menu. Using the up (↑) or down (↓) buttons, move the cursor (>) to Set Clock and press (↵) to enter this menu.

EXIT > Set Clock Set Hardness Set Recharge Time

2. Use the up (↑) and down (↓) buttons to set the correct time, being sure AM or PM shows, as applicable. Up (↑) advances the time; down (↓) moves the time backward.

Set Clock: 9:32PM ↑↓ Change	↵ Exit
-----------------------------------	--------

3. When the correct time shows, press Menu/Exit (↵) to set the clock and return to the primary menu. Using the up (↑) or down (↓) buttons, move the cursor (>) to EXIT and press Menu/Exit button (↵) and return to the normal operating screen.

Water Flow Rate: 2.0 GPM	9:32 PM ↵ Menu
--------------------------------	-------------------

FEATURES AND OPTIONS

RECHARGE: By pressing this button, the controller enters into the recharge menu. The options are Online/Offline, Recharge Now or Recharge Tonight. Move the cursor (>) next to selection and press Menu/Exit (↵) button. Online/Offline allows a specific tank to be put online or taken offline. In the Recharge Now menu, you can select one or all tanks to start an immediate recharge. Move the cursor (>) next to the specific tank and press the Menu/Exit (↵) button. This will toggle between Service and Scheduled. In the Recharge Tonight menu, you can schedule a recharge or cancel a recharge tonight. Move the cursor (>) next to the specific tank and press the Menu/Exit (↵) button. This will toggle between Service or Tonight.

>EXIT Online/Offline Recharge Now Recharge Tonight

The following is a description of the features and options in the Primary Menu. To enter the Primary Menu, press the Menu/Exit (↵) button. Using the up (↑) or down (↓) button, move the cursor to the feature or option that you would like to change and press the Menu/Exit (↵) button to enter screen. To return to the normal operating screen, move the cursor (>) to EXIT and press Menu/Exit button (↵).

SET SALT LEVEL: This is activated if Salt Monitor feature is set to ON. Using the up (↑) or down (↓) button, set the salt level number from 0 to 10 or pressing the down (↓) button past 0 will toggle Salt Monitor to OFF. This number corresponds with the numbered decal on the brinewell that the salt level is closest to. Press the Menu/Exit (↵) button to set and return to the Primary menu. Note: This feature is not shown if System Type is set to Filter.

Set Salt Level: 8 ↑↓ Change	↵ Exit
-----------------------------------	--------

SET CLOCK: Use the up (↑) and down (↓) buttons to set the correct time. If 12 hour clock is set, be sure AM or PM shows, as applies. Up (↑) advances the time; down (↓) moves the time backward. By pressing and holding either the up (↑) or down (↓) button, the display will scroll at faster increments. Press the Menu/Exit (↵) button to set and return to the Primary menu.

Set Clock: 9:32PM ↑↓ Change	↵ Exit
-----------------------------------	--------

SET HARDNESS: (Softeners only) Using the up (↑) or down (↓) button, set the water hardness level, from 1 to 160 grains, or 10 to 2740 PPM (parts per million). By pressing and holding either the up (↑) or down (↓) button, the display will scroll at faster increments. Move the cursor (>) to EXIT and press Menu/Exit button (↵) and return to the normal operating screen.

Set Hardness: 25 Grains ↑↓ Change	↵ Exit
-----------------------------------------	--------

SET RECHARGE TIME: Using the up (↑) or down (↓) button, set the time when regenerations should start. Press the Menu/Exit (↵) button to set and return to the Primary menu. Move the cursor (>) to EXIT and press Menu/Exit button (↵) and return to the normal operating screen. Note: This feature is available only on single or multiple units operating in parallel delay.

Set Recharge Time: 2:00 AM ↑↓ Change	↵ Exit
-----------------------------------------------	--------

continued

FEATURES AND OPTIONS

FLOW RATE: This screen is for viewing the flow rate, in GPM or LPM, through each individual tank, depending on the configuration (simplex, duplex, etc.). Press the Menu/Exit (↵) button to return to the Primary menu. Move the cursor (>) to EXIT and press Menu/Exit button (↵) and return to the normal operating screen.

T1: 2.5 GPM	↵ Exit
T2: 3.1 GPM	
T3: 1.6 GPM	
T4: 2.8 GPM	

WATER USED TODAY: This screen displays the number of gallons or liters that have been used in each individual tank per 24 hour time period, depending on the configuration (simplex, duplex, etc.). Press the Menu/Exit (↵) button to return to the Primary menu. Move the cursor (>) to EXIT and press Menu/Exit button (↵) and return to the normal operating screen.

T1: 5 Gallons
T2: 8 Gallons
T3: 4 Gallons
T4: 6 Gallons

AVE DAILY WATER USE: This screen displays the *average* number of gallons or liters that have been used in a 24 hour time period. Press the Menu/Exit (↵) button to return to the Primary menu. Move the cursor (>) to EXIT and press Menu/Exit button (↵) and return to the normal operating screen.

System Average Daily Water Use: 300 Gallons	↵ Exit
---------------------------------------------------	--------

CAPACITY REMAINING: This screen displays the percent capacity remaining in each individual tank, depending on the configuration (simplex, duplex, etc.). Press the Menu/Exit (↵) button to return to the Primary menu. Move the cursor (>) to EXIT and press Menu/Exit button (↵) and return to the normal operating screen. Note: Not available for filters that have Filter Gallons set to OFF (step 19). Screen will show “Filtering Water”.

Capacity Remaining %: T1: 25% T3: 48% T2: 33% T4: 37%	↵ Exit
--------------------------------------------------------------------	--------

Filtering Water	12:22PM	↵ Exit
-----------------	---------	--------

SET 12/24 HOUR CLOCK: Using the up (↑) or down (↓) button, set the time to either a 12 or 24 hour clock. Press the Menu/Exit (↵) button to set and return to the Primary menu. Move the cursor (>) to EXIT and press Menu/Exit button (↵) and return to the normal operating screen.

Set 12/24 Hour Clock: 12 Hour	↵ Exit
↑↓ Change	

SET ENGLISH/METRIC: Using the up (↑) or down (↓) button, set the controller to measure in English or Metric units. Press the Menu/Exit (↵) button to set and return to the Primary menu. Move the cursor (>) to EXIT and press Menu/Exit button (↵) and return to the normal operating screen.

Set English/Metric	
English	
↑↓ Change	↵ Exit

SET ROLLING SCREEN: Using the up (↑) or down (↓) button, set this ON or OFF. If set to ON, the normal operating screen will scroll from Soft Water Available, which shows the capacity remaining in each tank, to Water Flow Rate and Salt Level is Low (if applicable). If there is a recharge scheduled, Recharge Tonight will also be displayed. Press the Menu/Exit (↵) button to set and return to the Primary menu. Move the cursor (>) to EXIT and press Menu/Exit button (↵) and return to the normal operating screen.

Set Rolling Display Screens OFF	↵ Exit
↑↓ Change	

REMOTE STATUS: This is a new optional feature for use. A remote monitor can be conveniently placed for viewing your conditioners status. This screen will show if the remote monitor setting has been turned on, and the status of the system (OK, low salt, check system). Press the Menu/Exit (↵) button to set and return to the Primary menu. Move the cursor (>) to EXIT and press Menu/Exit button (↵) and return to the normal operating screen.

Remote: Installed Status: System OK	↵ Exit
----------------------------------------	--------

SEND SERVICE MESSAGE: This option may or may not be available. Press the Menu/Exit (↵) button and the controller automatically starts sending the service message in a series of beeps to be transmitted by phone. The display shows the how much of the message has been sent and a progress bar. To cancel the transmission press the Menu/Exit (↵) button. When message has been sent, the controller returns to the normal operating screen. Contact your installer for more information on service messages.

Sending Message	
56%	
	↵ Exit

continued

FEATURES AND OPTIONS

ADVANCED SERVICE: By entering these menus, a warning screen will first be displayed. Only technicians or knowledgeable users should access these menus.

WARNING: Changes could affect unit performance.
 ↑ Continue ↓ Cancel

The following is a description of the features and options in the Advanced/Service Menu. To enter the Advanced/Service Menu, press the Menu/Exit (↵) button. Using the up (↑) or down (↓) button, move the cursor to Advance/Service and press the Menu/Exit (↵) button. The warning screen will show, press the up (↑) button to continue. To return to the Primary Menu, move the cursor (>) to EXIT and press Menu/Exit button (↵).

SET LANGUAGE: Using the up (↑) or down (↓) buttons, move the cursor (>) next to the preferred language. Press the Menu/Exit (↵) button to select and return to the Advance/Service Menu screen.

> English
 Español
 Français
 ↑↓ Change ↓ Exit

DIAGNOSTICS: This screen is for viewing only and will show any error codes plus information on each individual tank, depending on the configuration (simplex, duplex, etc.). Move the cursor (>) next to the specific tank and press the Menu/Exit (↵) button. Press the Recharge button and the valve will step through each cycle of the valve. Use the up (↑) or down (↓) buttons to view all lines of the screen. Press Menu/Exit button (↵) to return to the diagnostics screen.

>EXIT
 Tank 1: Online
 Tank 2: Online
 Tank 3: Online

12:04:48PM Error0 ↑
 Pos: SERVICE 0:00
 Req Pos: SERVICE
 Motor: ON Sw:OPEN ↓

TEST REMOTE: At set up, the unit will send a signal to the remote every 3 seconds to allow for correct positioning of remote monitor. Press Menu/Exit (↵) to exit. Press the Menu/Exit (↵) button to return to the Advance/Service Menu screen. Note: This feature is not available if the optional remote is not installed in the controller.

Test Remote:
 Sending Message
 ↓ Exit

During normal operation, the green LED will flash at intervals of 5 seconds. If the unit requires salt, the amber LED will flash, and if the unit needs to be checked the red LED will flash.

The controller on the unit will send a signal to the remote monitor every minute. The remote monitor will listen for a signal every 10 minutes. Any changes in softener status could possibly take up to 10 minutes before the remote registers the change. If the unit stops sending a signal, the remote will keep trying to listen for the signal. If after 10 minutes with no signal received, the remote will try 1 minute later and 2 minutes later to find the signal, gradually increasing the time between, but will keep trying to listen for the signal for up to 2 days. After 20 minutes with no signal received, the remote monitor will turn off the LED's to conserve battery life, but will still be active. After 2 days with no signal received, the remote monitor will shut down until the reset button is pushed (on back of remote).

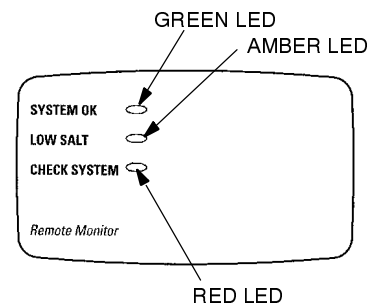

The remote uses 3 “AAA” batteries, which are included. To check batteries, press reset button on back of remote monitor. If batteries are good, the LED's on the remote should scroll green, amber, red. If LED's do not light, batteries need to be changed.

If there is another unit within range of the remote, it may cause a conflict with the channel that the remote monitor is receiving. If the remote monitor displays the wrong message (example: low salt when salt is above warning level) this is an indication that the remote monitor is receiving a different signal. Follow the steps below to change the remote channel.

NOTE: This device complies with Part 15 of the FCC Rules. Operation is subject to the following two conditions: (1) this device may not cause harmful interference, and (2) this device must accept any interference received, including interference that may cause undesired operation. Changes or modifications not expressly approved by the party responsible for compliance could void the user's authority to operate the equipment.

SET REMOTE CHANNEL: Press (↑) or (↓) to select a new channel from 1 to 16. Press the Menu/Exit (↵) button to select, and press reset button on back of remote monitor. Note: This feature is not available if a remote is not installed.

Set Remote
 Channel:
 13
 ↑↓ Change ↓ Exit

continued

FEATURES AND OPTIONS

SET LOW SALT ALERT: Press (↑) or (↓) to change Alert Level from 0 to 4. This number corresponds with the numbers on the brinewell. When the salt level falls below this level the controller will signal that salt needs to be added to the brine tank. Press the Menu/Exit (↵) button to select and return to the Advanced/Service menu. Note: Not available if System Type (step 5) is set to Filter.

Set Low Salt Alert Level: 2	↵ Exit
↑ ↓ Change	

SET MAX DAYS/RECHARGE: Press (↑) or (↓) to change Max Days Between Recharges. If Automatic is selected, the algorithm will determine when to recharge. If 1 to 15 is selected, the unit will never go past the number of days set for a recharge, but could recharge before. Press the Menu/Exit (↵) button to select and return to the Advanced/Service menu.

Set Max Days Between Recharges: Automatic	↵ Exit
↑ ↓ Change	

SET 97% FEATURE: Press (↑) or (↓) to set either OFF or On. If ON is selected, the unit will automatically recharge when 97% capacity has been used, at any time of the day. Press the Menu/Exit (↵) button to select and return to the Advanced/Service menu. Note: This feature is available for single tank or Parallel Delayed configurations only.

Set 97% Recharge Feature: OFF	↵ Exit
↑ ↓ Change	

SET CHLORINE/BYPASS: This feature is for European units. Press (↑) or (↓) to set on Bypass, Chlorine—Half Wave or Chlorine—Full Wave. Press the Menu/Exit (↵) button to select and return to the Advanced/Service menu.

Set Chlorine/ Bypass	↵ Exit
Bypass	
↑ ↓ Change	

VALVE CONFIGURATION: This option allows you to reprogram the controller. After all valve configuration selections have been made, all other settings (clock, water hardness, etc.) will need to be reset. Note: The controller will also reset all counts back to zero (number of recharges, etc.), except for the number of days in service.

Set Valve Type: Two Inch Upflow	↵ Next
↑ ↓ Change	

EXTERNAL SOLENOID DURING REGENERATION

Step 1

A. Remove (from existing valve assembly):

1. screws, and wire cover
2. base flat strip, existing guard plate

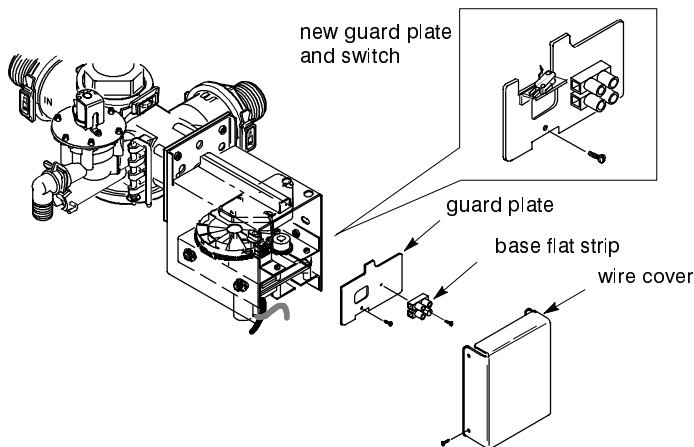

B. Install:

1. switch and screws, included in kit, and base flat strip on new guard plate
2. new guard plate on valve assembly and replace mounting screw
3. wire cover, *after* making wiring connections

Step 2 – typical electrical connection:

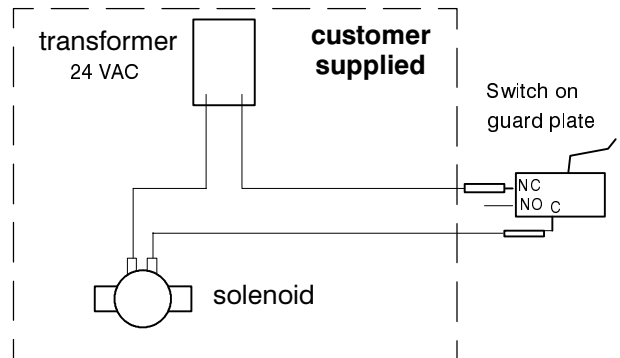

SERVICE / REGENERATION VALVE CYCLE SEQUENCE

Upflow Softener, set to Single, Peak Flow, Parallel Immediate or Parallel Delayed:

Service ⇨⇨ Fill ⇨⇨ Brine ⇨⇨ Backwash ⇨⇨ Fast Rinse ⇨⇨ Service

Upflow Softener, set to Alt. Immediate:

Service ⇨⇨ Fill ⇨⇨ Brine ⇨⇨ Backwash ⇨⇨ Fast Rinse ⇨⇨ Standby

Note – After the first tank has regenerated, it stays in standby and does not return to service until the second tank needs regeneration. The second tank regenerates, then remains in standby and does not return to service until the first tank again requires regeneration.

Filter, set to Single, Peak Flow, Parallel Immediate or Parallel Delayed:

Service ⇨⇨ Backwash ⇨⇨ Fast Rinse ⇨⇨ Service

Filter, set to Alt. Immediate:

Service ⇨⇨ Backwash ⇨⇨ Fast Rinse ⇨⇨ Standby

Note – After the first tank has backwashed and rinsed, it stays in standby and does not return to service until the second tank needs cleaning. The second tank backwashes and rinses, then remains in standby and does not return to service until the first tank again requires cleaning.

Downflow Softener, set to Single, Peak Flow, Parallel Immediate or Parallel Delayed:

Service ⇨⇨ Fill ⇨⇨ Backwash ⇨⇨ Brine ⇨⇨ Fast Rinse ⇨⇨ Service

Downflow Softener, set to Alt. Immediate:

Service ⇨⇨ Fill ⇨⇨ Backwash ⇨⇨ Brine ⇨⇨ Fast Rinse ⇨⇨ Standby

Note – After the first tank has regenerated, it stays in standby and does not return to service until the second tank needs regeneration. The second tank regenerates, then remains in standby and does not return to service until the first tank again requires regeneration.

VALVE POSITION DECAL (located on bottom of controller drive mechanism)

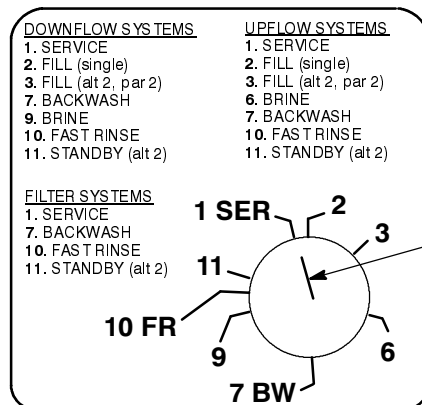

indicator mark on bottom of gear (shown in service position)

OPERATION – WATER FLOW THROUGH CONDITIONER

SERVICE

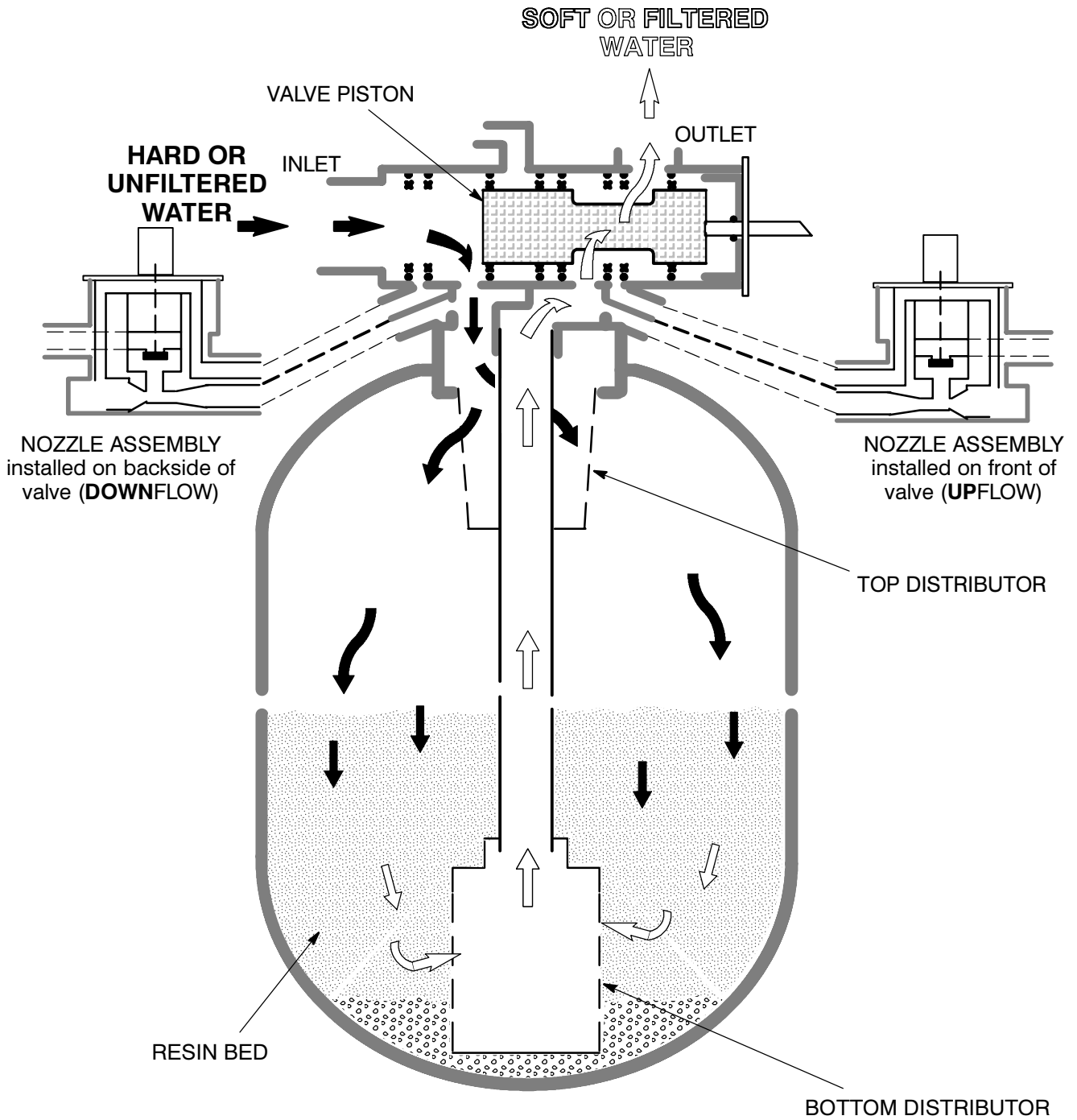

OPERATION – WATER FLOW THROUGH CONDITIONER

FILL (softener only) *Single Tank*

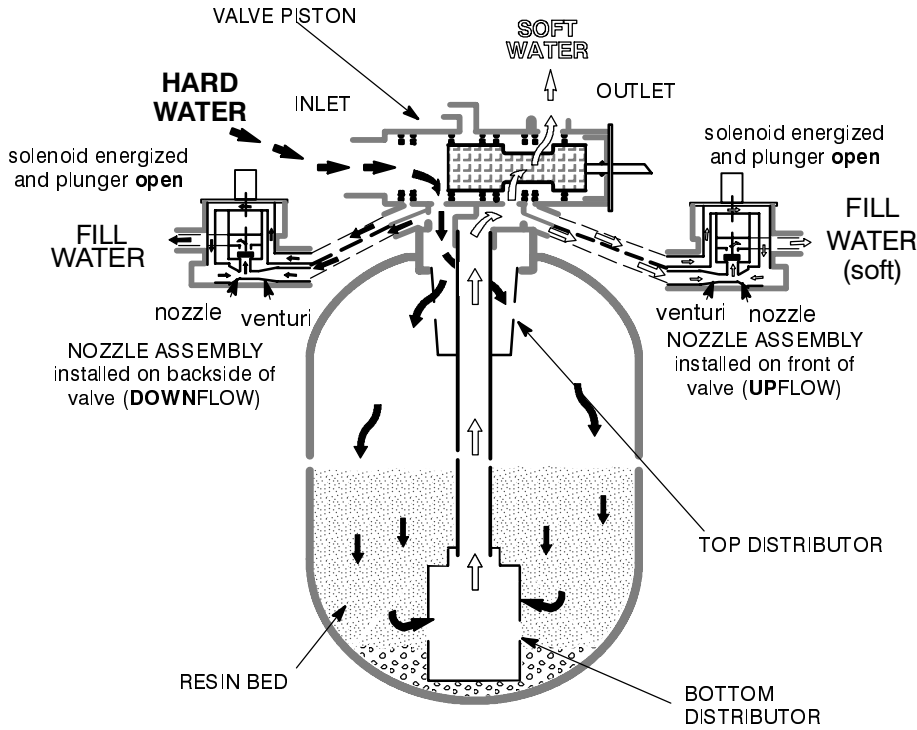

FILL (softener only) *Multiple Tank*

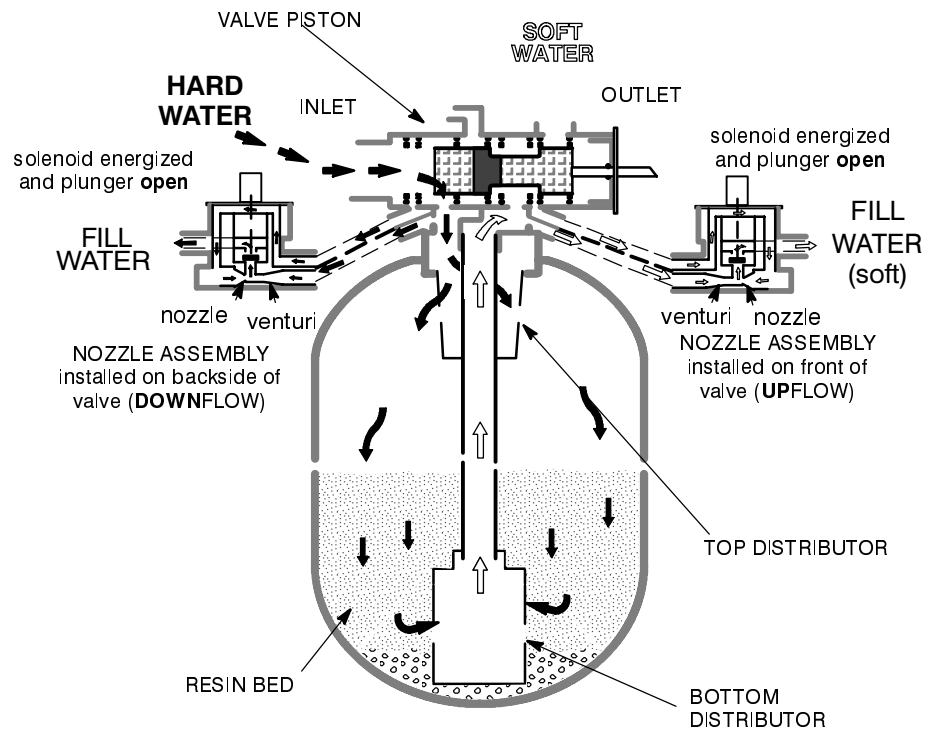

OPERATION – WATER FLOW THROUGH CONDITIONER

UP-FLOW BRINING and BRINE RINSE Single Tank (softener only)

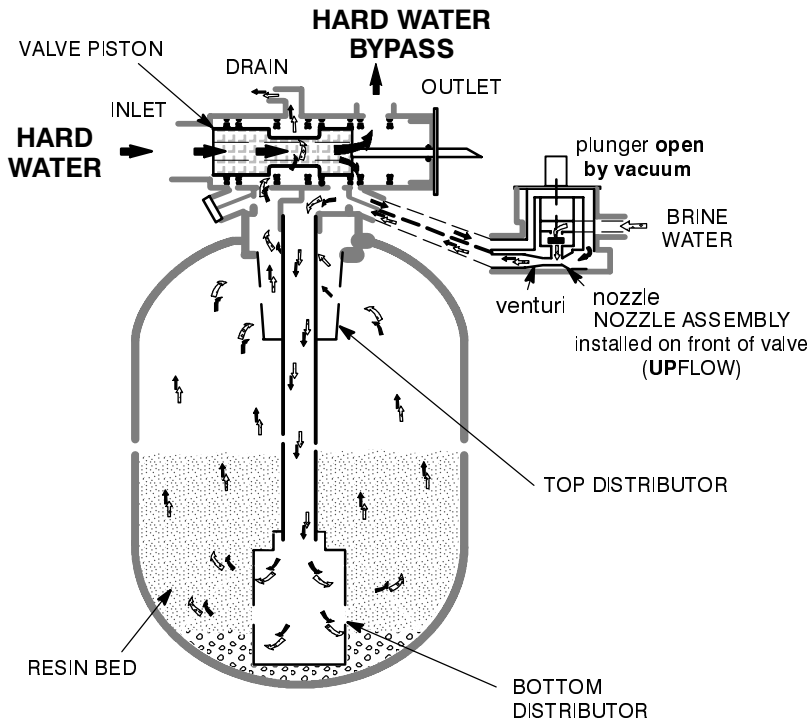

UP-FLOW BRINING and BRINE RINSE Multiple Tank (softener only)

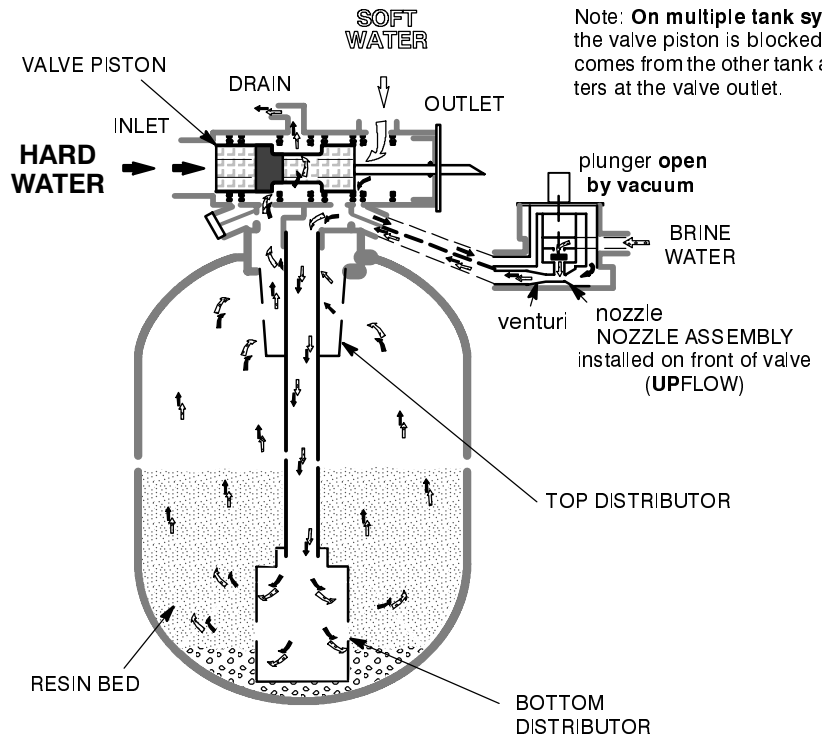

Note: On multiple tank systems, the valve piston is blocked. Water comes from the other tank and enters at the valve outlet.

OPERATION – WATER FLOW THROUGH CONDITIONER

DOWN-FLOW BRINING and BRINE RINSE Single Tank (softener only)

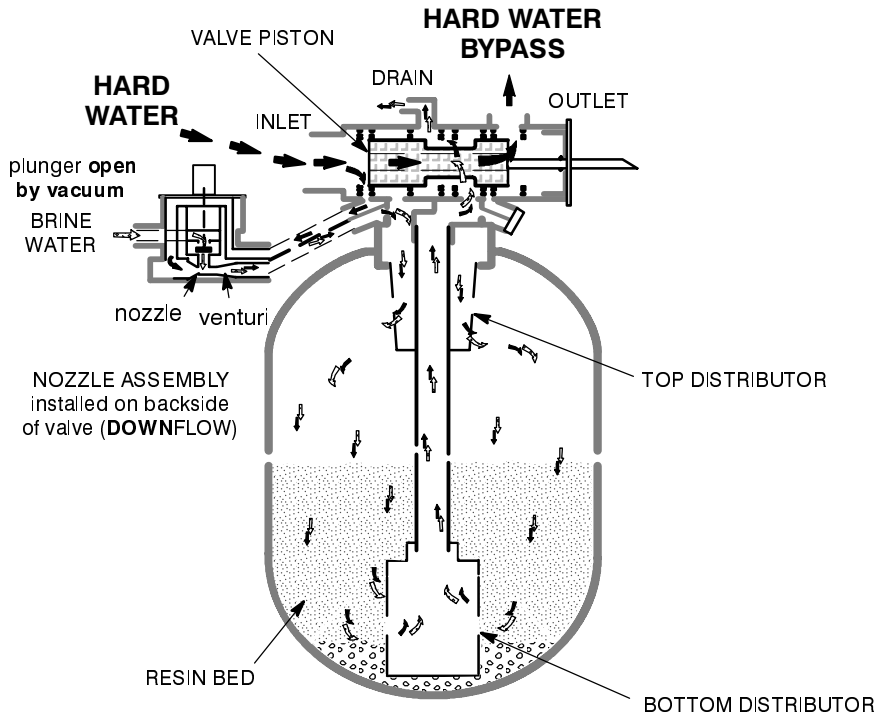

DOWN-FLOW BRINING and BRINE RINSE Multiple Tank (softener only)

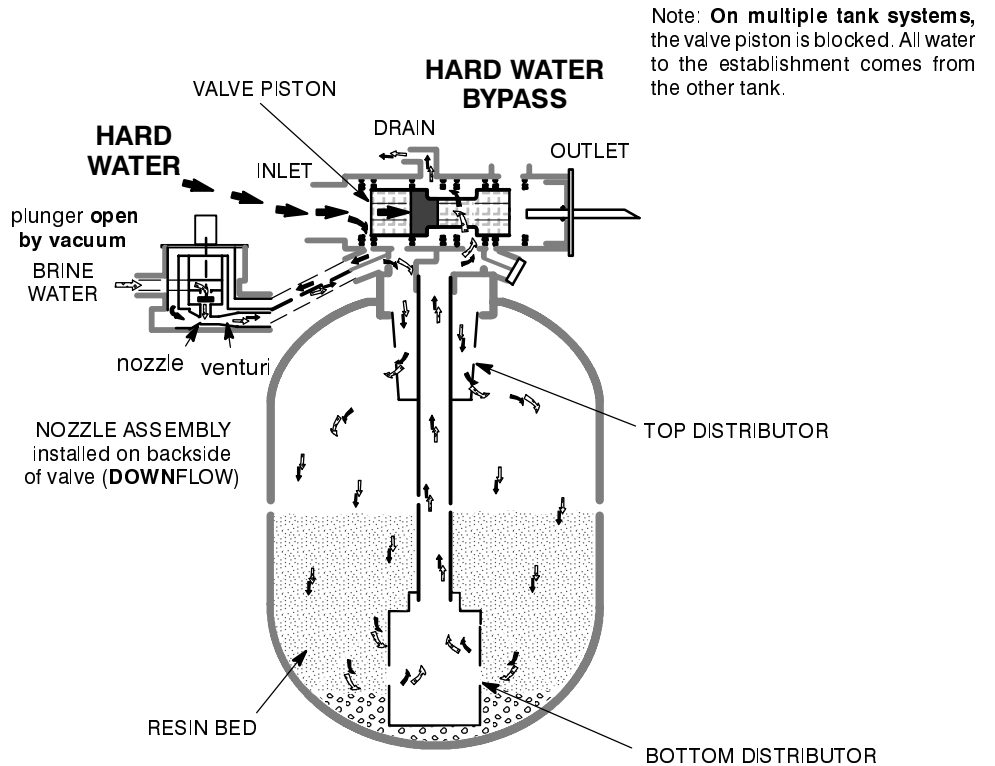

OPERATION – WATER FLOW THROUGH CONDITIONER

BACKWASH Single Tanks

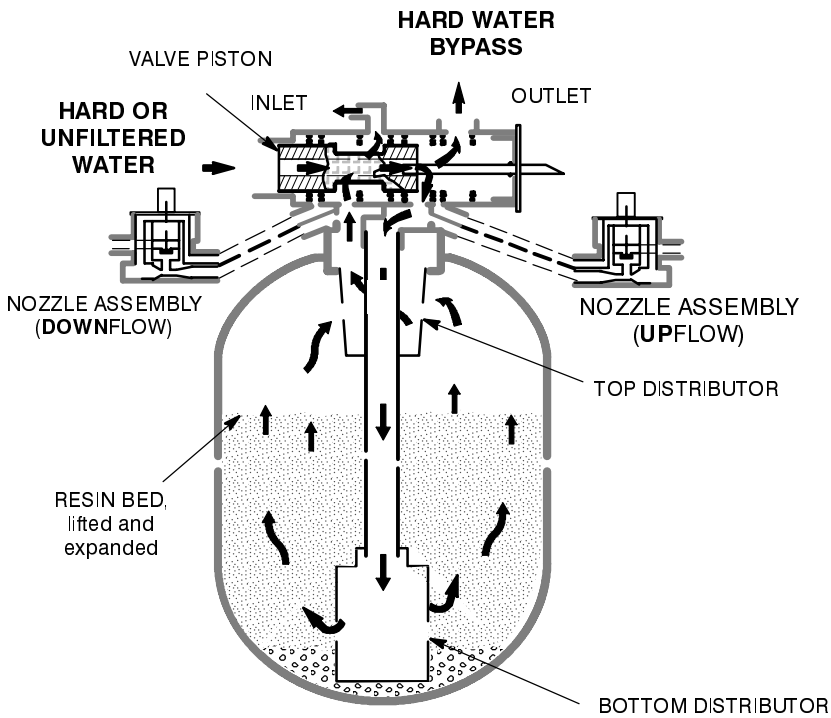

BACKWASH Multiple Tanks

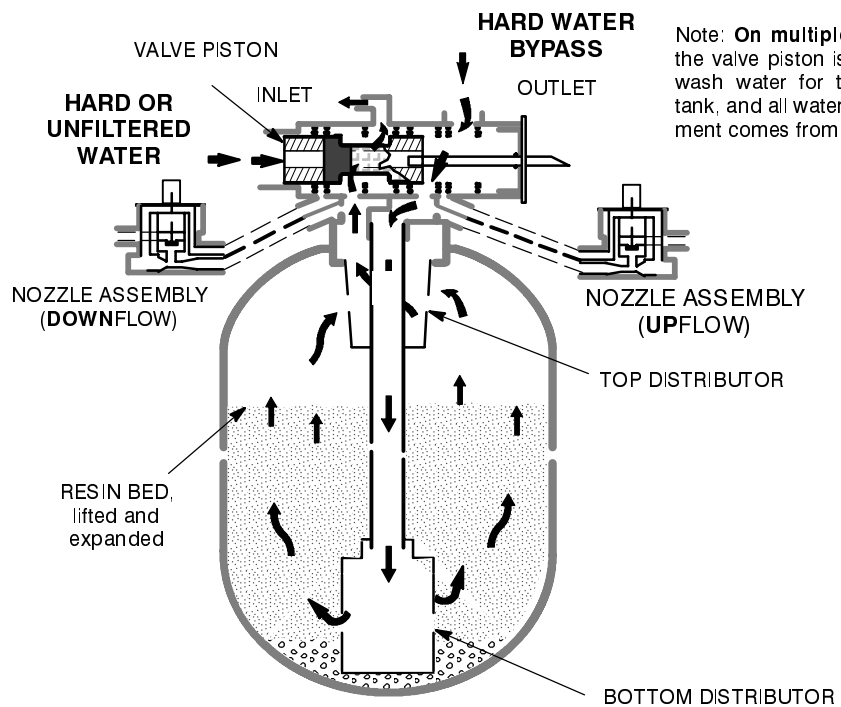

OPERATION – WATER FLOW THROUGH CONDITIONER

FAST RINSE *Single Tanks*

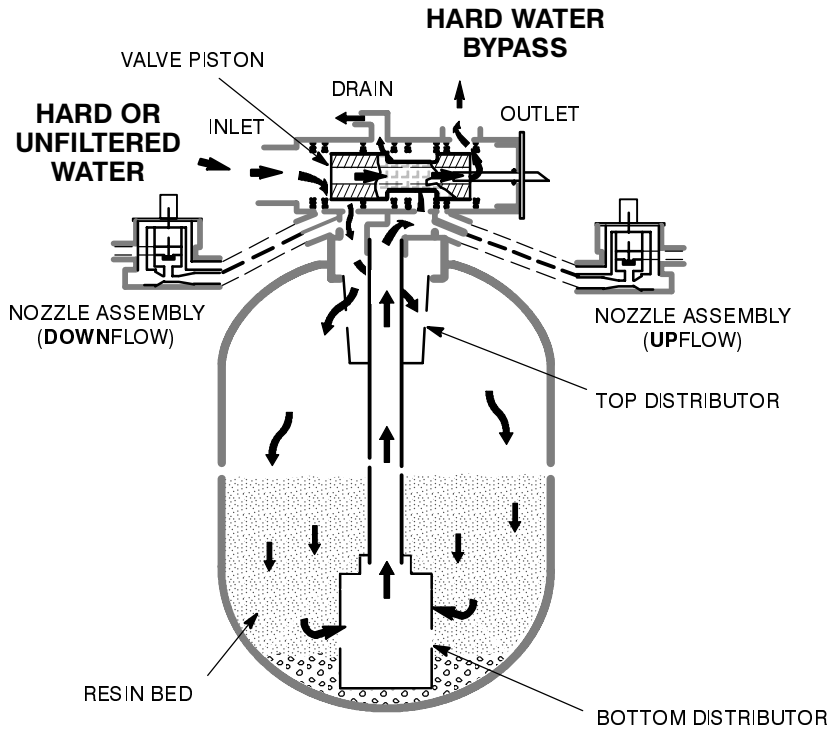

FAST RINSE *Multiple Tanks*

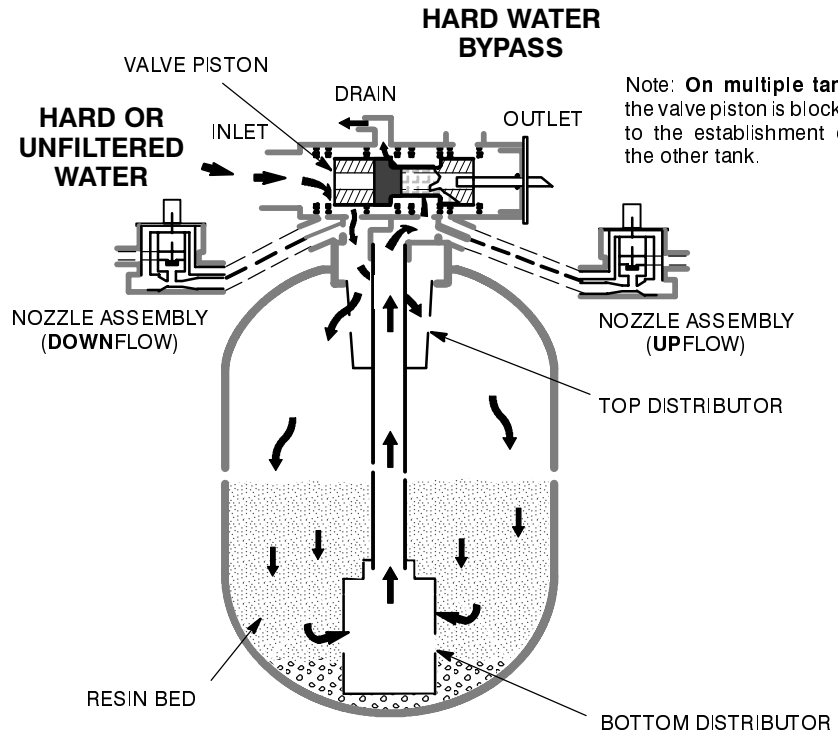

OPERATION – WATER FLOW THROUGH CONDITIONER

STAND-BY NO WATER FLOW

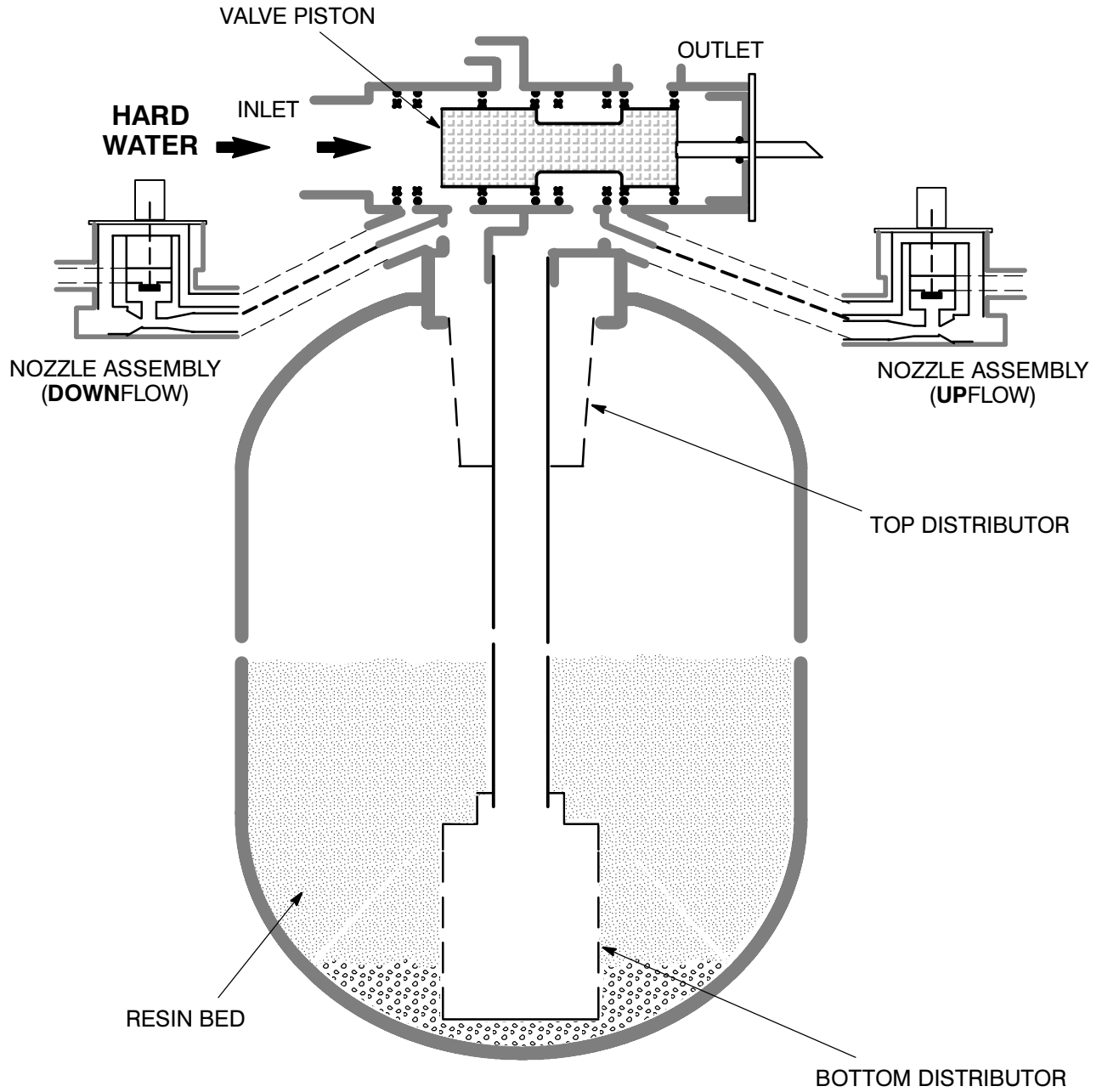

OPERATION – WATER FLOW THROUGH CONDITIONER

STAND-BY (UP-FLOW, Multiple Unit Installation)

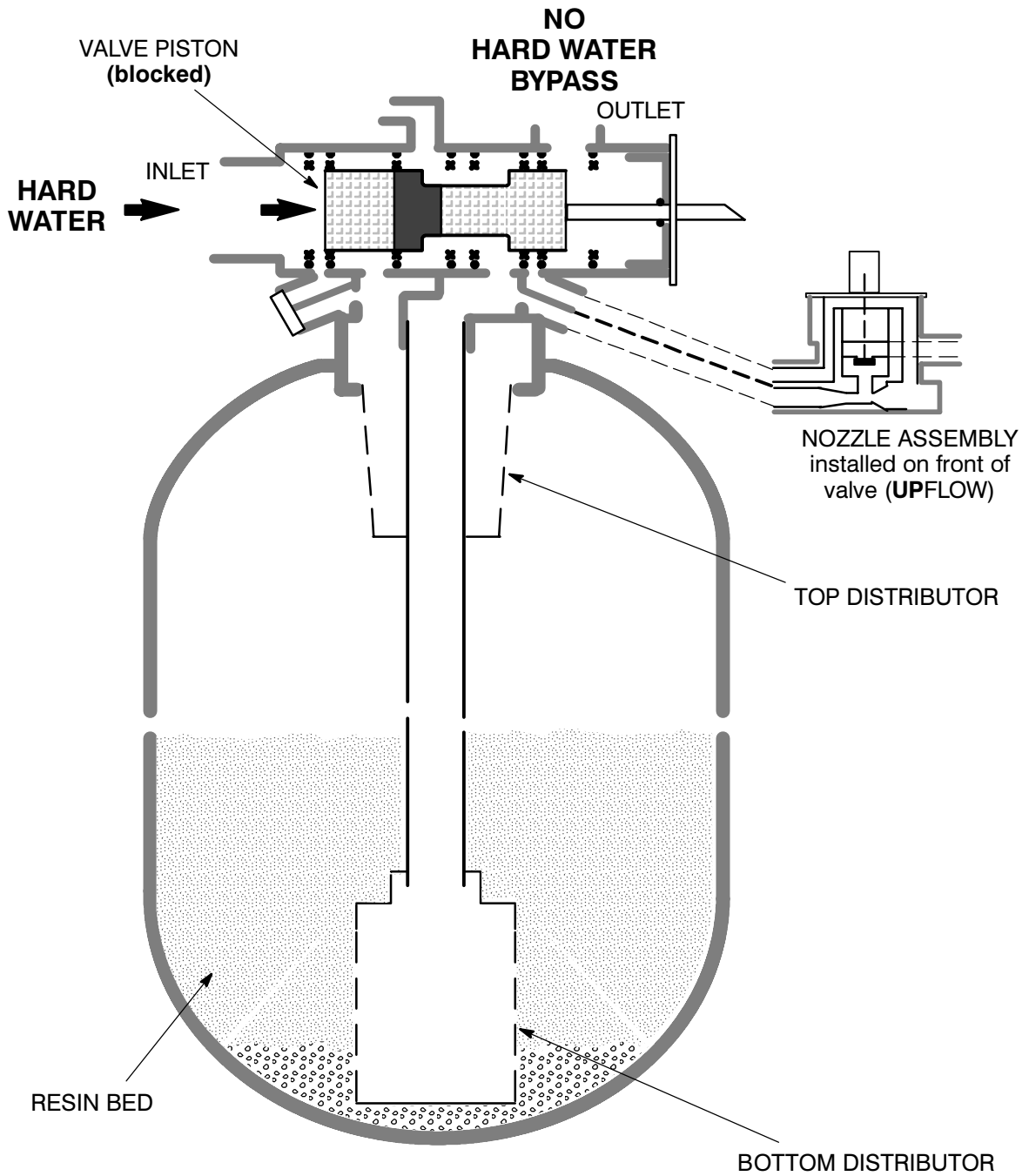

OPERATION – WATER FLOW THROUGH CONDITIONER

STAND-BY (DOWN-FLOW, Multiple Unit Installation)

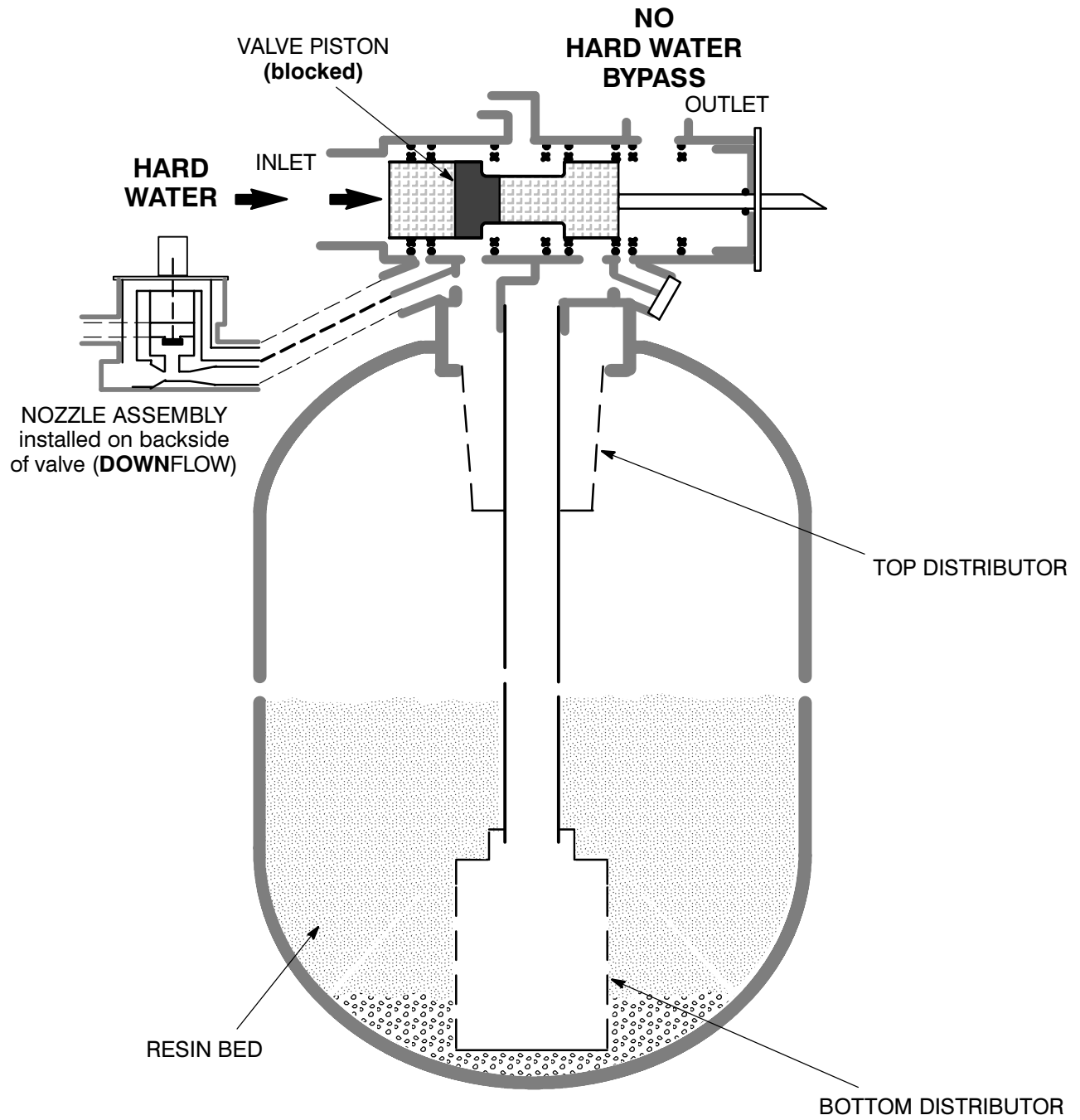

MAINTENANCE

REFILLING WITH SALT

Remove the brine tank cover and check the salt storage level frequently. Refill if less than 1/2 full. In humid areas, it is best to keep the salt storage level lower, and to refill more often. **Be sure the brinewell cover is on.**

RECOMMENDED SALT: Nugget, pellet, button, coarse solar, etc., water conditioner salt is recommended. This type of salt is from high purity evaporated crystals, sometimes formed, or compressed, into briquets. It has less than 1% insoluble (will not dissolve in water) impurities. *Clean, high grade* rock salts are acceptable, but may require frequent brine tank cleaning to remove the “sludge” residue (insolubles).

SALT NOT RECOMMENDED: Rock salt, high in impurities, block, granulated, table, ice melting, ice cream making salts, etc., are not recommended.

SALT WITH IRON REMOVING ADDITIVES: Some salts have an additive to help a water conditioner handle iron in a water supply. Although this additive may help keep the resin bed clean, it may also release corrosive fumes.

BREAKING A SALT BRIDGE

Sometimes, a hard layer or salt bridge forms in the brine tank. They are usually caused by high humidity. If such a layer occurs, salt will not dissolve in the water to make brine. Without brine, the resin bed does not regenerate and you will have hard water.

If the storage tank is full of salt, it is hard to tell if you have a salt bridge. Salt is loose on top, but the bridge is under it. Take a broom handle, or like tool, and push it straight down into the salt. If a hard object is felt, it's most likely a salt bridge. *Carefully* push into the bridge in several places to break it. **Do not pound** on the tank walls.

CLEANING NOZZLE / VENTURI, and SCREENS

Clean nozzle, venturi, refill flow control and screens are needed for the softener to work properly. The nozzle and venturi creates the suction to transfer brine solution from the brine tank, into the resin tank. If either should become plugged with iron, sand, silt, dirt, etc., the brine will not get to the resin bed to regenerate it, and you will get hard water.

To clean the nozzle and venturi, refer to the drawing below. **Be sure to turn off water to the softener and relieve pressure . . . see next page** (no water pressure at aspirator assembly). Then, to clean parts, including all screens, disassemble as shown. Scrub using hot, soapy water and a soft brush. Use care not to scratch or misshape holes in the nozzle and venturi. **Be sure to check the screen in the brine elbow.**

Carefully replace all parts in the correct order. If the refill flow control was disassembled, be sure the flow plug is securely retained by the holder. Lubricate o-ring seals with silicone grease and locate in position. Replace u-pins, retaining clips and the brine elbow clip. Turn on the water and check operation.

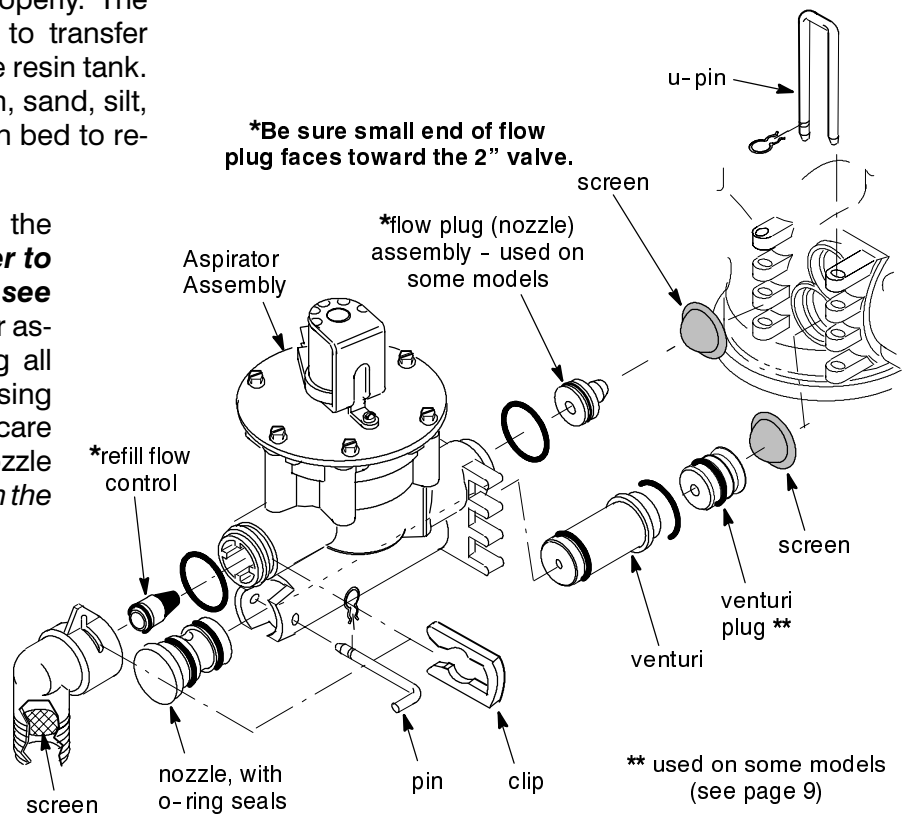

MAINTENANCE

TO RELIEVE WATER PRESSURE

CAUTION: To prevent personal injury, or damage to conditioner parts, be sure to do the following steps, in exact order, before working on the valve assembly.

► SINGLE TANK SYSTEM:

1. Check the valve cycle indicator on the bottom of the controller drive mechanism. If not in “service” position, first do step 2. If already in “service”, go to step 3.

2. Press the Recharge button and go to the Recharge menu. Move the cursor (>) to Recharge Now and press Menu/Exit button. Move the cursor (>) to Tank 1, press Recharge to start a recharge now. Press the Recharge button to cycle valve to service position.

>EXIT Online/Offline Recharge Now Recharge Tonight

3. **Open** the plumbing **bypass valve**, and **close** the **inlet** and **outlet** plumbing **valves**.

4. Press the Recharge button to advance the valve to **fill** position. Water will bleed out of the resin tank and valve, into the brine tank.

5. *Wait until flow to the brine tank stops.* Then unplug the transformer. This will prevent accidental advancing of the mechanism and or piston while working on the controller.

► MULTIPLE TANK SYSTEM:

1. At the tank you will service, check the valve cycle indicator on the bottom of the controller drive mechanism. If not in **fill** position, first do step 2. If already in fill, go to step 3.

2. Read the caution below. Then, press the Recharge button and go to the Recharge menu. Move the cursor (>) to Recharge Now and press Menu/Exit button. Move the cursor (>) to Tank 1, press Recharge to start a recharge now. Press the Recharge button to cycle valve to fill position.

>EXIT Online/Offline Recharge Now Recharge Tonight

3. **Open** the plumbing **bypass valve**, and **close** the **inlet** and **outlet** plumbing **valves**. Water will bleed out of the resin tank and valve, into the brine tank.

4. *Wait until flow to the brine tank stops.* Then, disconnect the controller power cord from the bottom of the electronic box. This will prevent accidental advancing of the mechanism and or piston while working on the controller.

► SINGLE OR MULTIPLE TANK SYSTEM, AND NO ELECTRICAL MEANS TO ADVANCE VALVE:

1. Close the system main water supply valve to turn off water to the softener or filter tank(s).

2. Open plumbing *bypass valve(s)* and a nearby downstream faucet on soft or filtered water.

3. When flow from faucet stops, close **all** *inlet* and *outlet* plumbing *valves*.

Caution, multiple tank systems may have an optional blocked piston to prevent bypass water during regenerations: Never cycle the valve, when pressurized, with the plumbing bypass valves closed. Damage to the valve, drive mechanism, and motor may occur if water, displaced by the valve piston, can not enter nearby plumbing. **Be sure plumbing valves are open to all tanks before advancing a valve to the next cycle.**

MAINTENANCE

DISASSEMBLY / ASSEMBLY PROCEDURES (continued)

Most of the disassembly and assembly steps are obvious when you look at the part or group of parts, and at the parts illustrations throughout this manual. Special procedures are listed below.

CAUTION: To prevent personal injury, or damage to conditioner parts, be sure to turn off the water and relieve pressure (see previous page) before working on the valve assembly or resin tank. The brine valve assembly is pressurized only during the fill cycle of regeneration.

➔ Removing valve assembly from resin tank:

1. Be sure to follow procedures above to turn off the water supply and depressurize the conditioner.
2. Remove clamp retainers and clamp sections at the valve inlet, outlet and drain (be sure all piping is supported).
3. Carefully separate the 2" nipples, with o-ring seals, from the valve.
4. Remove both retainers and clamps holding the valve to the resin tank adaptor.
5. Lift the valve up and off.

➔ Removing top distributor from resin tank:

1. Do preceding steps 1 – 5.

Important: When doing the next step, reach through the top distributor support and hold the bottom distributor down while lifting up on the support (refer to fig. 2, page 7). Use a blunt ended tool like a nut driver to hold it down. Do not use a screw driver or other sharp tool that will damage plastic parts. This will keep the distributor in place and not allow it to lift out of the resin bed. If it lifts, it is difficult to push to the bottom of the tank again because of the gravel base.

2. While holding the top distributor in place, carefully pry upward on the top distributor support and remove from the tank adaptor.
3. Lift the top distributor and screen up and out. Again, be careful not to lift the bottom distributor.

➔ **Proper alignment** of Valve Piston with Drive Mechanism and Timer: It is possible for the controller drive mechanism to get "out of alignment" with the valve piston. This can occur if...

...the valve is disassembled for repairs.
...the bolts (see below) that hold the inner bracket assembly in place, loosen.

When out of alignment, you may notice poor brine draw characteristics, and/or hard water "bleed" from a conditioner in standby.

TO ALIGN:

1. Use the manual advance procedures (page 40) to cycle the valve into **backwash**. Verify by observing the decal on the bottom of the drive mechanism, and a fast flow to the drain.

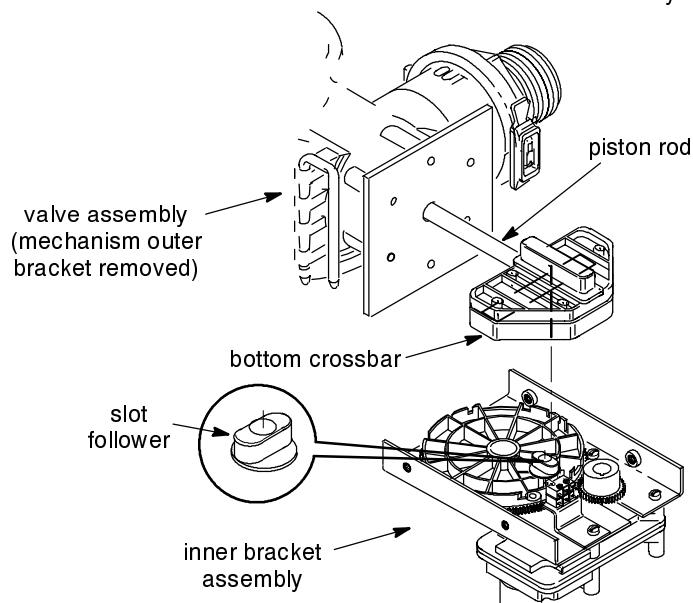
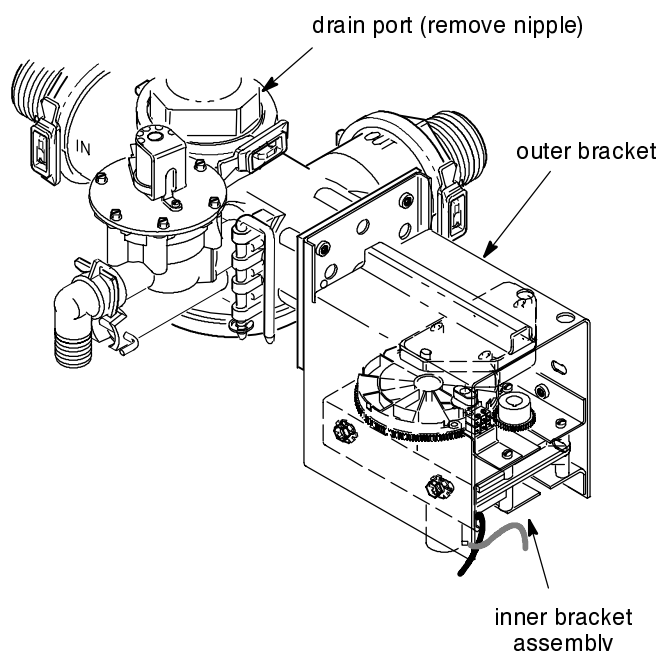

MAINTENANCE

2. Place plumbing bypass valves in bypass position (see page 11). Pressure will vent to the drain.

Caution: On multiple tank systems, the inlet side of the valve remains pressurized. See page 34 to relieve **all** pressure.

3. Unplug the transformer. This will prevent accidental cycling to the next position.

4. *Loosen* the 4 hex-head screws holding the inner bracket assembly in place (see drawing on previous page).

5. Remove retainers and pull the u-pins holding the aspirator assembly in place. Remove the aspirator assembly and screens from the valve.

Note: You can also check for piston alignment, with alignment marks, at the alternate aspirator assembly mounting location (remove plug), or at the drain port (remove drain nipple).

6. Look into the the bottom aspirator port. The back edge of the piston must align with one of the marks on the exposed ribs of a lantern ring. If it does not, push or pull on the inner bracket assembly (slides in elongated holes in outer bracket) until aligned.

NOTE: If properly aligned, elongated holes in the outer bracket will center over threaded holes in the inner bracket.

7. Tighten all hex-head screws and lock washers to fasten the inner bracket in place.

8. Plug the transformer back in, pressurize and verify correct operation using the manual advance procedures.

➔ **Valve seal and ring locations:** Locate lantern rings, quad ring seals and o-ring seals exactly as shown below.

Notes: Be sure to install the far, right hand most o-ring seal onto the end plug. *Do not* install on the lantern ring. — Only 7 *quad-ring* seals are used in the valve, on multiple tank systems, as shown below.

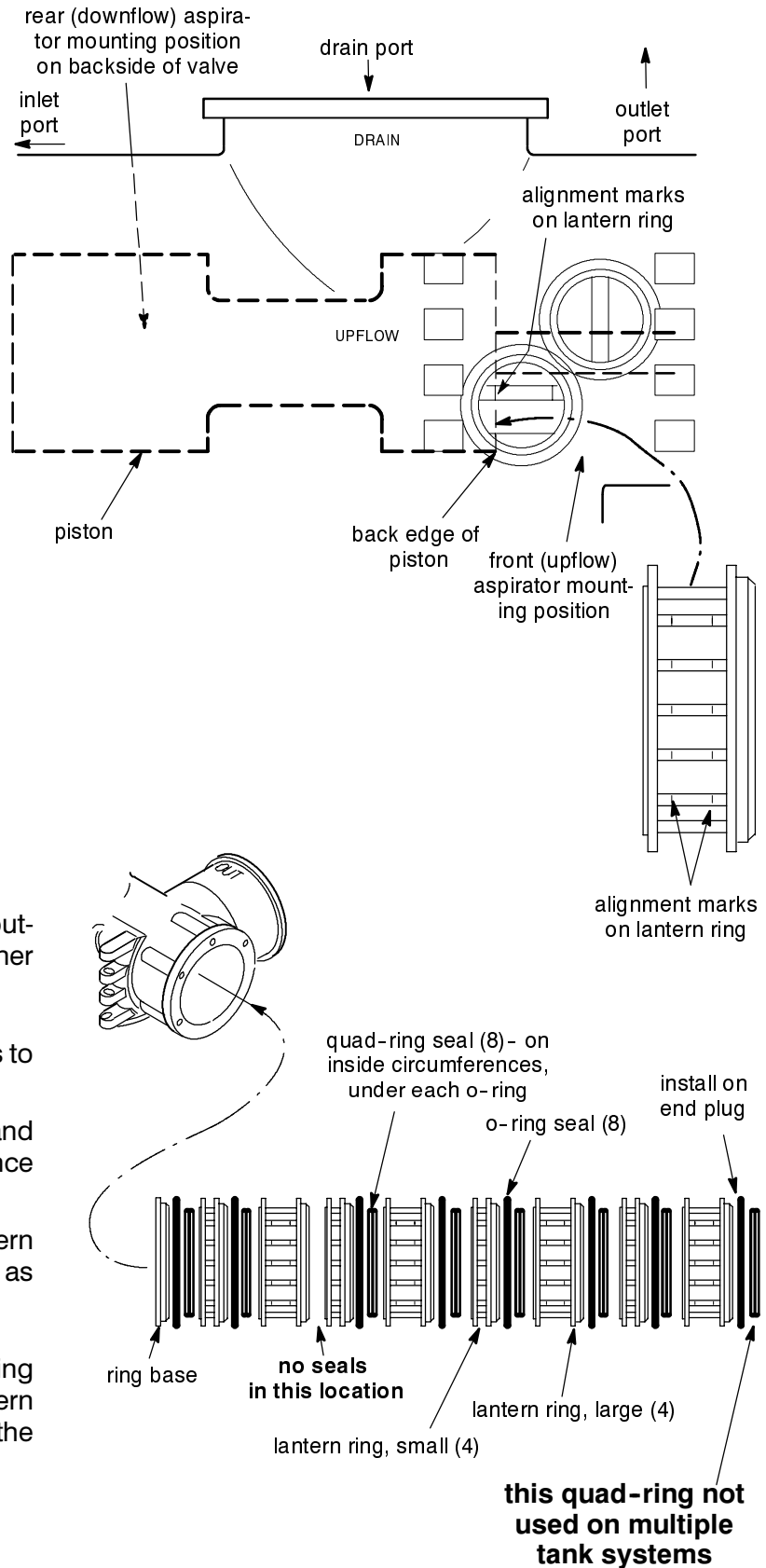

MAINTENANCE

WIRING CONNECTION DIAGRAM

*NOTE: Multiple units require only one transformer.

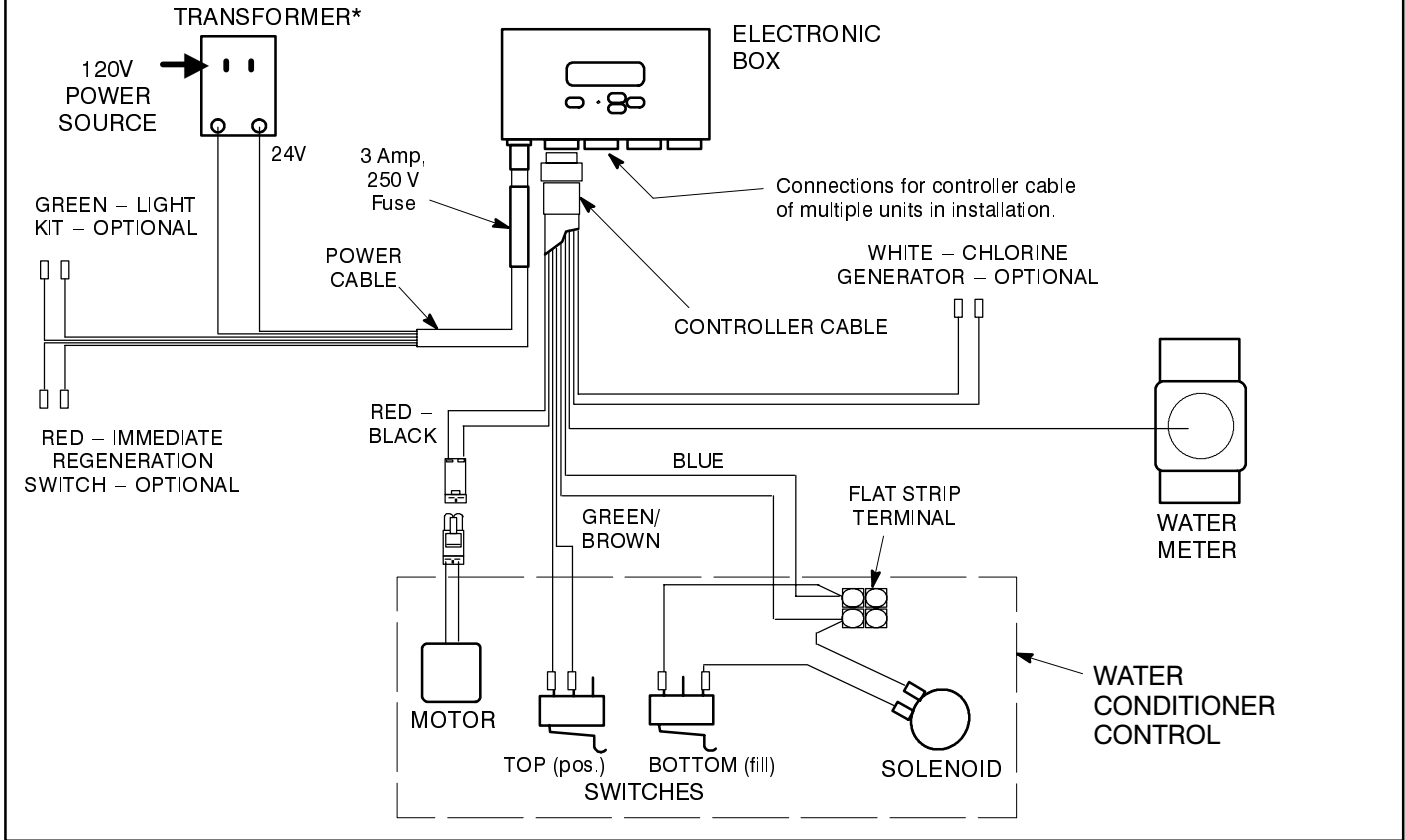

ELECTRONIC BOX / CONTROLLER FACEPLATE

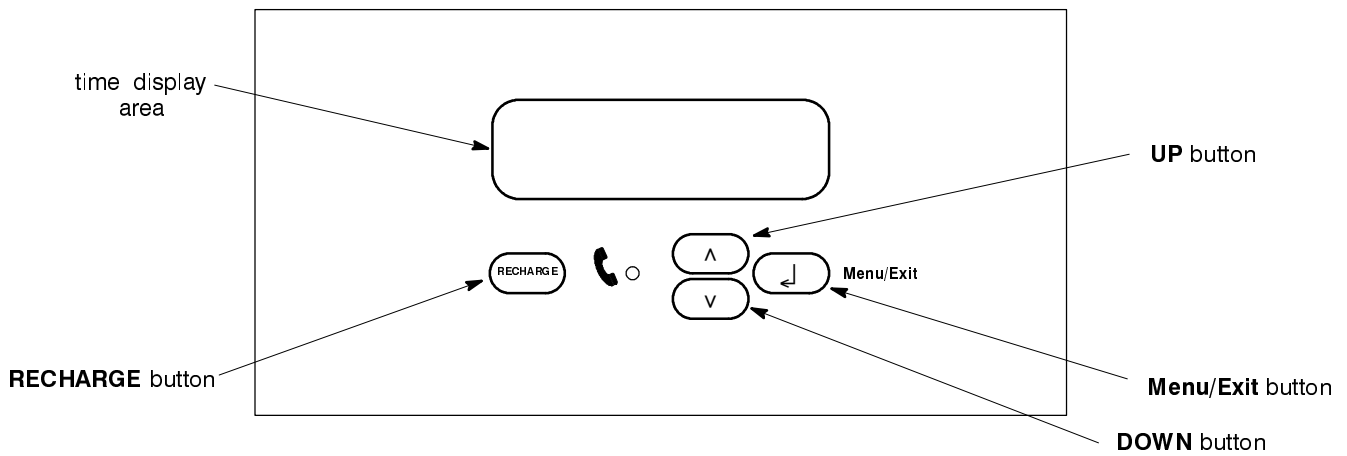

MAINTENANCE / TROUBLESHOOTING

ALWAYS MAKE THE INITIAL CHECKS FIRST:

1. Does the time display show the correct time of day?
...If display is blank, check power source to the conditioner.
...If display is blank, check the fuse on the power cord.
...If time is flashing, power was off for longer than the built-in program memory. The conditioner resumes normal operation, when power returns, but regenerations occur at the wrong time.
...If an error code shows in the display (example: Error3), go to AUTOMATIC ELECTRONIC DIAGNOSTICS, below.
2. Plumbing bypass valve(s) must be in service position (all the way open or closed, as applies. . . see page 11).
3. Inlet outlet and drain pipes must connect to the conditioner as typically shown on page 11.
4. Is the transformer plugged into a “live”, grounded wall outlet, and the power cable fastened securely?
5. Is there salt in the brine tank? Check to be sure it is not bridged or caked (see page 33).
6. Is the brine tubing connected? See step 5, page 12.
7. Double check the Hardness setting. Press the Menu/Exit (↵) button, move the cursor (>) to Set Hardness and press the Menu/Exit (↵) button. Be sure it is the correct setting for the water supply. Make a hardness test of the raw water and compare with the hardness setting. If the water contains iron, be sure to add 5 to the hardness number for each 1 ppm. Also test a conditioned water sample to verify if a problem exists. Press the Menu/Exit (↵) button to return to Primary menu, move cursor to EXIT and return to normal operating screen.

If you do not find a problem after making the initial checks, do MANUAL ELECTRONIC DIAGNOSTICS, and the MANUAL ADVANCE REGENERATION CHECK following.

AUTOMATIC ELECTRONIC DIAGNOSTICS

The timer computer has a self-diagnostic function for the electrical system (except input power and water meter). The computer monitors electronic components and circuits for correct operation. If a malfunction occurs, an error code appears in the timer display area of the electronic box.

Error # 3 Tank #1 Recharge to Retry ↵ Menu

The chart on the next page shows the error codes that could appear, and the possible defects for each code. While an error code appears in the display, the tank is taken offline and either the Recharge button or Menu/Exit (↵) can be used. Menu/Exit (↵) remains operational so the service person can use the Manual Electronic Diagnostics screen to further isolate the defect, and check the water meter.

If Recharge is pressed, the display will show the diagnostics screen and cycle the valve through all positions to try to correct the error itself. After it is done retrying, the display reverts back to the run screen (either showing error code again or normal run screens).

If the controller successfully fixes the problem in the diagnostics display, the unit automatically is placed back online by the software. There would be no need to go into the online/offline screen to put the unit back online.

continued on next page

MAINTENANCE / TROUBLESHOOTING

PROBLEM	POSSIBLE DEFECT	POSSIBLE SOLUTION
No display.	No power to outlet.	Check the outlet by plugging in another appliance.
	Fuse blown.	Check fuse in power cable. REPLACE WITH SAME TYPE AND VALUE: AGC 3A 250V.
	Internal transformer fuse blown.	Plug the transformer into an outlet and measure output voltage with a multi-meter. Should be between 24 and 30 volts AC.
Fuse keeps blowing.	Wiring harness shorted or not connected properly.	Check connections at controller box and valve. Connect all other wires before plugging transformer into outlet.
Error code 1, 3 or 4.	Wiring harness not connected or not connected properly.	Check connections at controller box and valve. Check for corrosion at connection points.
	Incorrect position switch connections.	Check valve switch connections.
	Incorrect valve type selected on new install or upgrade to system.	Check proper valve configuration is selected controller box.
	Valve motor running slow, or not at all.	Initiate a recharge and step valve through all positions. Check motor for consistent movement. If slow, check motor and valve seals; lubricate piston.
Error code 6	Optional immediate regeneration switch is stuck in the on position.	Check red wires from power cable for possible shorts, check immediate regeneration switch, if installed.

Procedure for removing error code from faceplate: Press the RECHARGE button, or: 1. Unplug transformer – – – 2. Correct defect – – – 3. Plug in transformer – – – 4. Wait for 6 minutes. The error code will return if the defect was not corrected.

MANUAL ELECTRONIC DIAGNOSTICS

1. Do the preceding (page 38) INITIAL CHECKS first.

2. Enter the diagnostics screen on the controller (page 21) and using the down (↓) button, view the turbine information.

Pos: SERVICE 0:00	↑
Req Pos: SERVICE	
Motor: ON Sw: OPEN	
Trbn: 000 Gals: 0	↓

The 3 digits after “Trbn:” indicate water meter operation as follows.

000 (steady) = conditioned water not in use...no flow through the meter.

- open a nearby conditioned water faucet -

000 to 45 (continual) = repeats display for each gallon of water passing through the meter.

If you don't get a reading in the display, check the turbine connection to the electronic box. If the connection is okay and good contact is made, turn off the water supply and remove the turbine / sensor assembly (4 screws) from the water meter body. Check the turbine for obstruction or binding. If okay and you still **do not get a reading**, the sensor is probably defective.

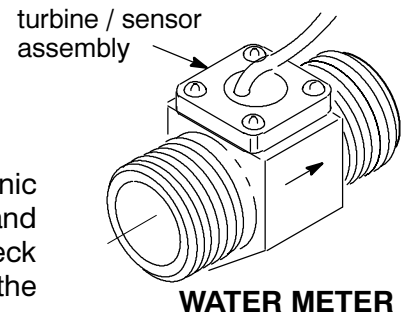

NOTE: When the position or regeneration switch lever and plunger are depressed, the switch is closed.

MAINTENANCE

TROUBLESHOOTING, MANUAL ADVANCE REGENERATION CHECK

This check verifies proper operation of the gear–motor, brine tank fill, brine draw, regeneration flow rates, and other controller functions. *Always make the initial checks, and the manual initiated diagnostics first.*

NOTES: (1) A steady time (not flashing) must show in the display. (2) Refer to the valve cycle chart on page 22 for cycle sequences. (3) To verify the valve position, look at the decal on the bottom of the controller.

Caution, multiple tank systems with blocked pistons to prevent bypass water during regenerations: Never cycle a valve, when pressurized, with the plumbing bypass valves closed. Damage to the valve, drive mechanism, and motor may occur if water, displaced by the valve piston, can not enter nearby plumbing. **Be sure plumbing valves are open to all tanks before advancing a valve to the next cycle.**

1. Use the recharge button to manually advance the valve into each cycle and check the various valve cycles. Move the cursor next to the tank and press the Recharge button. The valve will start the sequence for recharge. Press the Recharge button to advance the valve through each position.

>EXIT Recharge Now Recharge Tonight

FILL: Remove the brinewell cover and, using a flashlight, observe fill water entering the tank.

NOTE: The aspirator solenoid is energized and open during the fill cycle. You can usually hear the solenoid “click” and “buzz”.

a. If water does not enter the tank, look for an obstructed nozzle and venturi, fill flow control, screen(s), brine tubing or defective solenoid.

CAUTION: Softener must be depressurized before removing aspirator assembly.

BRINING: A slow flow of water to the drain will begin. Verify brine draw from the brine tank by shining the flashlight into the brinewell and observing a noticeable drop in the liquid level.

NOTE: Be sure water is in contact with the salt, and not separated by a salt bridge...see page 33.

a. If the unit does not draw brine, check for...
...dirty or defective nozzle and venturi, page 33
...restriction in valve drain, causing a back-pressure (bends, kinks, elevated too high, etc.)
...obstruction in brine valve or brine tubing
...inner valve failure (obstructed or defective o–ring / quad–ring seals, piston)

BACKWASH: Look for a fast flow of water from the drain.

a. If flow is slow, check for a plugged top distributor screen, internal riser pipe, backwash flow controls, drain piping, fouled resin bed, etc.

FAST RINSE: Again look for a fast drain flow. Allow the unit to rinse for several minutes to flush out any brine that may remain from the brining cycle test.

2. To return the valve to service position, press Recharge button once again.

Note: On multiple tank systems, the first tank advances to service before the second tank then manually advances to fill and all other cycles.

NOZZLE / FLOW PLUG USAGE AND IDENTIFICATION CHART

SOFTENER MODEL	Regen. Water Flow	FILL CONTROL / NOZZLE, VENTURI REQUIREMENTS				DRAIN FLOW CONTROL REQUIREMENTS				
		Water ① Pressure	Nozz. / Venturi color	Flow Plug gpm/color	Sleeve Req'd (small)	Fill Plug gpm / color*	Flow Plug gpm/color* (bkw./rns.)	Sleeve Req'd (large)	Solid Plugs Req'd	Assembly Part Number
102 132 162	Upflow	low	purple	-	-	1.0 / green	7 / brown	yes	3	7193309
		med	purple	.6 / blue	yes					
		high	green	.4 / lt. blue	yes					
	Downflow	low	black	-	-	1.0 / green	7 / brown	yes	3	7193309
		med	red	-	-					
		high	gray	-	-					
192 252 322	Upflow	low	red	1.0 / green	yes	2.0 / brown	12 / red	no	3	7193317
		med	gray	-	-					
		high	red	.8 / orange	yes					
	Downflow	low	yellow	-	-	2.0 / brown	12 / red	no	3	7193317
		med	black	-	-					
		high	red	-	-					

* On most flow plugs, identification is by a colored dot on black rubber.

① See pressure ranges on page 10.

	MODEL					
	102	132	162	192	252	322
FILL CYCLE FLOW RATE (GPM)	1.0 / green	1.0 / green	1.0 / green	2.0 / brown	2.0 / brown	2.0 / brown
FILL FLOW PLUG LOCATION	See page 33 in manual					
BRINE CYCLE FLOW RATE (GPM)	.58	.57	1.1	1.1	1.1	1.1
BR. RNS. CYCLE FLOW RATE (GPM)	.48	.47	.89	.89	.89	.89
BKW. CYCLE, & FAST RNS. CYCLE FLOW RATE (GPM)	7	7	7	12	12	12
BKW. F. RNS. FLOW PLUG IDENTIFICATION, AND LOCATION	7 / brown			12 / red		
	See drain adaptor					
AMOUNT GRAVEL (LBS.)	FINE	50	50	50	100	100
	MED.	50	50	50	100	100
* FREEBOARD (INCHES)	25	18	24	37	29	21

* Nominal distance from top of resin bed, to top of the tank. This dimension can vary several inches, depending on resin moisture content, degree of bed expansion or packing, resin tank diameter tolerances, etc.

BRINING/BR. RNS. CYCLE TIME (MIN.)◆	LOW SALT	115	150	180	110	145	180
	HIGH SALT	95	125	154	80	120	150
BACKWASH CYCLE TIME (MIN.) □		12	12	12	14	14	14
FAST RINSE CYCLE TIME (MIN.) □		5	5	5	10	10	10

□ Factory default setting.....see page 18.

◆ Cycle times for upflow brining. For downflow brining, see page 18.

DRAIN FLOW CONTROL REQUIREMENTS					
FILTER MODEL	Filter Type	Flow Rate (gpm)	Flow Plug gpm/color*	Solid Plugs Req'd	Asm. Part Number
172 Filter	carbon	15	15 / black	3	7195319
	greensand / multi-media	24	12 / red (2)	2	7193325
242 Filter	carbon	30	15 / black (2)	2	7195327
	greensand / multi-media	50	15 / black (2) 20 / blk-wht dot	1	7195335

REPAIR PARTS LIST

KEY NO.	PART NUMBER	DESCRIPTION
1	7175678	Reducer, 3/4" x 1/2"
2	7138210	Conn., 1/2" NPT x 1/2" Tube (2)
○	7190377	Tubing, 1/2" x 8 ft. (not shown)
3	7170296	O-ring Seal, 2-7/8" x 3-1/4" (2)
4	7165291	Support, Top Distributor
5	9001100	O-ring Seal, 4.1 x 4-1/2" (2)
6	9001102	O-ring Seal, 2-3/8" x 2-3/4"
7	7165283	Top Distributor
8	7169813	Screen
9	7169902	Tank Adaptor
10	7145217	Clamp (2)
11	7088033	Clamp Retainer (2)
12	7243625	Distributor (bottom) Assembly
13	0502272	Resin, 1 cu. ft. ①
	3424509	Activated Carbon, 1 cu. ft. ①
	0501676	Mang. Greensand, 1 cu. ft. ①
	0993070	Anthracite (lb) ①
	0993090	Garnet (lb) ①
	0993080	Filter Sand (lb) ①
14	7124415	Gravel – Fine, 17 lbs. ①
	7124423	Gravel – Fine, 50 lbs. ①
	7127073	Gravel – Medium, 50 lbs. ①
	4104600	Gravel – Coarse, 17 lbs. ①
15	--	Tank Base
16	7149994	Resin Tank, 17" dia. x 58" ②
	7153561	Resin Tank, 17" dia. x 72" ②
	7139062	Resin Tank, 24" dia. x 72" ②
17	406018	Adaptor, 6" to 4" (36" x 72" tank)
18	7022207	Transformer, 24V – 50VA
19	7239854	Control Box
20	9006029	Screw, #6-20 x 5/16" (2)

KEY NO.	PART NUMBER	DESCRIPTION
21	0502080	Controller Mounting Bracket
22	7234846	Power Cable
23	7250478	Control Cable, without Water Meter Housing
24	0900386	Screw, #8-32 x 1/2" (4)
	0810037	Washer (4)
25	7251377	Water Meter Housing
26	--	Fuse, AGC 3A 250V – purchase locally – Replace with same type and value only 
27	7194622	Tee, 1/2" NPT – multiple tank sys.
28	7194630	Nipple, 1/2" NPT – multiple tank
29	7221940	Air Check, 41" high tank – includes brinewell key no. 31
	7222085	Air Check, 50" & 51" high tanks – includes brinewell key no. 31
30	0500283	Brinewell Cover
	7222051	Brinewell Cover, 51" high tanks
31	0980062	Brinewell, 41" high tank
	0980067	Brinewell, 50" and 51" high tanks
32	7243853	Decal, Brinewell
33	7227027	Brine Tank (w/cover), 24" x 50"
	7227035	Brine Tank (w/cover), 31" x 51"
34	0523819	Drain Elbow

ACCESSORIES

--	7242996	Remote Monitor Kit
--	7238735	Error Indicator
--	7238727	Controllor Extension Cable, 20'

① See page 2 for amounts required.

② Includes tank base.

VALVE, ASPIRATOR ASSEMBLIES

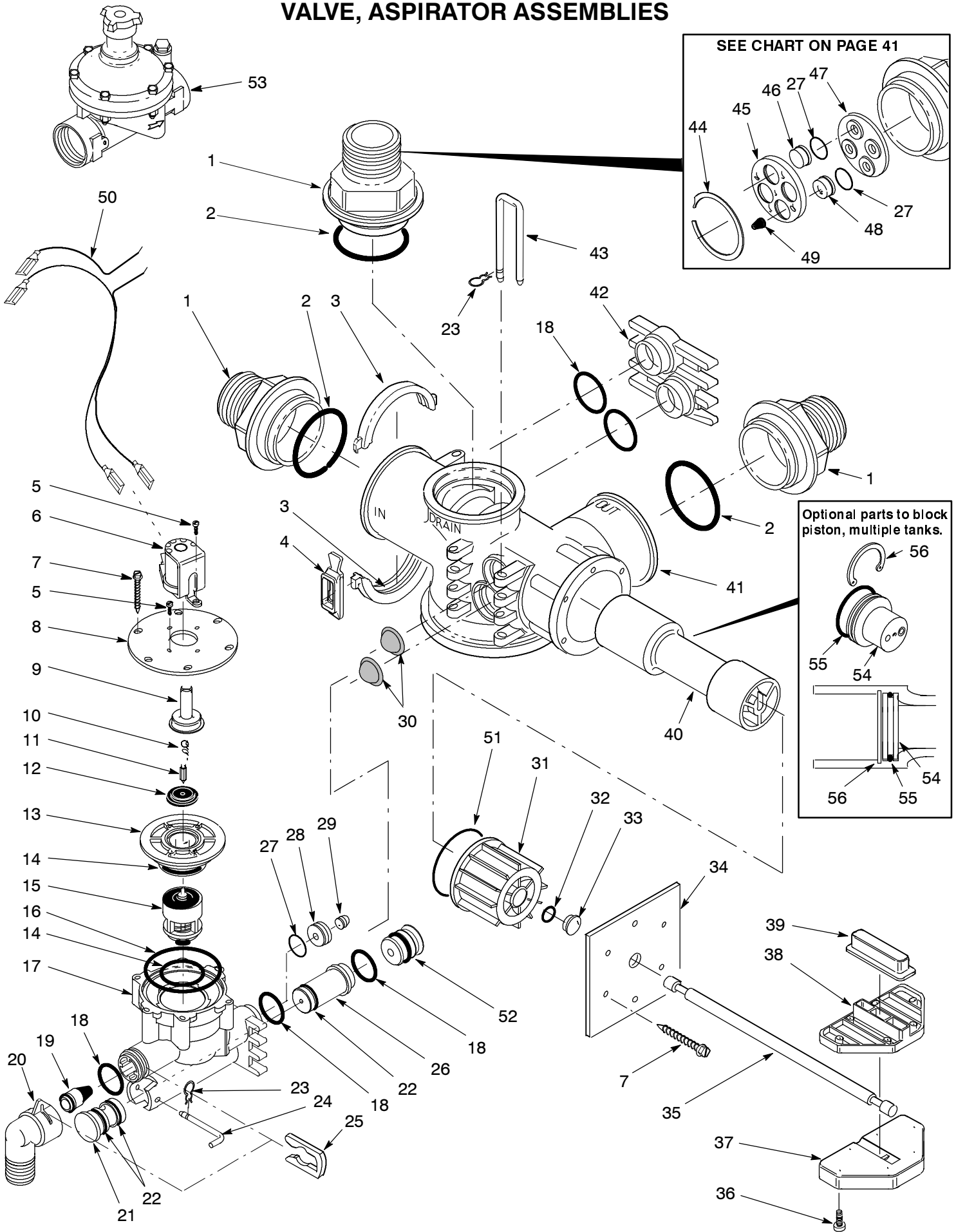

REPAIR PARTS LIST

KEY NO.	PART NUMBER	DESCRIPTION
1	7174460	2" Nipple, Inlet/Outlet (3)
2	7170296	O-ring Seal, 2-7/8" x 3-1/4" (3)
3	7176292	Clamp Section (6, 4 not shown)
4	7088033	Clamp Retainer (6, 5 not shown)
5	9006029	Screw, #6 - 20 x 5/16" (4)
6	7224192	Solenoid Coil, 24V
★	7196284	Solenoid Assembly (Includes key nos. 6, 9, 10, 11 and 12)
7	9006042	Screw, #10 - 14 x 1-1/4" (12)
8	7169368	Mounting Plate
9	7003334	Solenoid Guide
10	7003342	Solenoid Spring
11	7003350	Armature
12	7003368	Diaphragm
13	7168087	Aspirator Cap
14	7169886	O-ring Seal, 1-1/4" x 1-1/2" (2)
15	7195165	Plunger Assembly, consisting of:
	7169350	Diaphragm
	7168095	Plunger
	7168079	Retainer (Housing)
	7169342	O-ring Seal, 13/32" x 27/32"
16	9001102	O-ring Seal, 2-3/8" x 2-3/4"
17	7168061	Aspirator Housing
★	7195212	Aspirator Seal Kit (Includes key nos. 12, 14, 15, 18 and 22)
18	7168312	O-ring Seal, 1" x 1-1/4" (5)
19	7186598	Fill Flow Plug, green dot (1.0)
	7189033	Fill Flow Plug, brown dot (2.0)
	7189041	Fill Flow Plug, tan dot (3.0)
	7189059	Fill Flow Plug, purple dot (3.5)
20	7186580	Brine Elbow (with screen)
21	7170571	Nozzle, Red (.082)
	7170589	Nozzle, Black (.1)
	7170597	Nozzle, Yellow (.125)
	7170602	Nozzle, Blue (.156)
	7170610	Nozzle, Orange (.19)

KEY NO.	PART NUMBER	DESCRIPTION
21	7170628	Nozzle, White (.219)
	7170636	Nozzle, Green (.25)
	7179151	Nozzle, Gray (.062)
	7187447	Nozzle, Green (.043)
	7187455	Nozzle, Purple (.055)
22	7186572	O-ring Seal, 3/4" x 1" (3)
23	7180788	Retainer Clip (5)
24	7015852	Pin
25	7169180	Clip
26	7168100	Venturi, Red
	7169203	Venturi, Black
	7169211	Venturi, Yellow
	7169229	Venturi, Blue
	7169237	Venturi, Orange
	7169245	Venturi, White
	7169253	Venturi, Green (2-3/8" long)
	7179169	Venturi, Gray
	7187421	Venturi, Green (2-5/8" long)
7187439	Venturi, Purple	
27	7197206	O-ring Seal, 11/16" x 13/16"
28	7169326	Sleeve, Small
29	7187463	Flow Plug, light blue dot (.4)
	7187413	Flow Plug, blue dot (.6)
	7169570	Flow Plug, orange dot (.8)
	7169588	Flow Plug, green dot (1.0)
	7169596	Flow Plug, yellow dot (1.2)
30	7169376	Screen, Nozz/Vent. (2)
31	7174486	End Plug
32	7169839	O-ring Seal
33	7169392	Flanged Bushing
34	7169114	Mounting Bracket
35	7169473	Piston Rod
36	7173804	Screw, #10 - 32 x 1/2" (6)
37	7169130	Crossbar, Bottom
38	7169122	Crossbar, Top

continued next page

REPAIR PARTS LIST (continued)

KEY NO.	PART NUMBER	DESCRIPTION
39	7170563	Slot Follower, Rectangular
40	7176268	Piston
41	7218329	Valve Body
42	7168045	Aspirator Plug (2 req'd on filters)
43	1289000	U-pin (4)
44	7169538	Steel Ring (retainer)
45	7169261	Retaining Plate, Front
46	7180576	Plug, DFP Plate
47	7169279	Retaining Plate, Back
48	7169334	Sleeve, Large
49	7169716	Flow Plug, Brown (7.0)
	7169740	Flow Plug, Red Dot(12.0)
	7169758	Flow Plug, Black (15.0)
	7169774	Flow Plug, White Dot (20.0)

KEY NO.	PART NUMBER	DESCRIPTION
50	7169871	Solenoid Wiring
51	7169287	O-ring Seal
52	7211995	Venturi Plug
	7139478	O-ring Seal, 5/8" x 13/16"

Optional Accessories

53	7270567	External No Hard Water Bypass Solenoid Valve
–	7205172	Switch Kit for above solenoid valve
54	7229443	Pressure Relief Asm ①
55	7026552	O-ring Seal, 1.6" x 2" ①
56	7192769	Snap Ring ①

- ① Parts included in piston of multiple tank valve only.
- ② See assembly numbers, page 41.

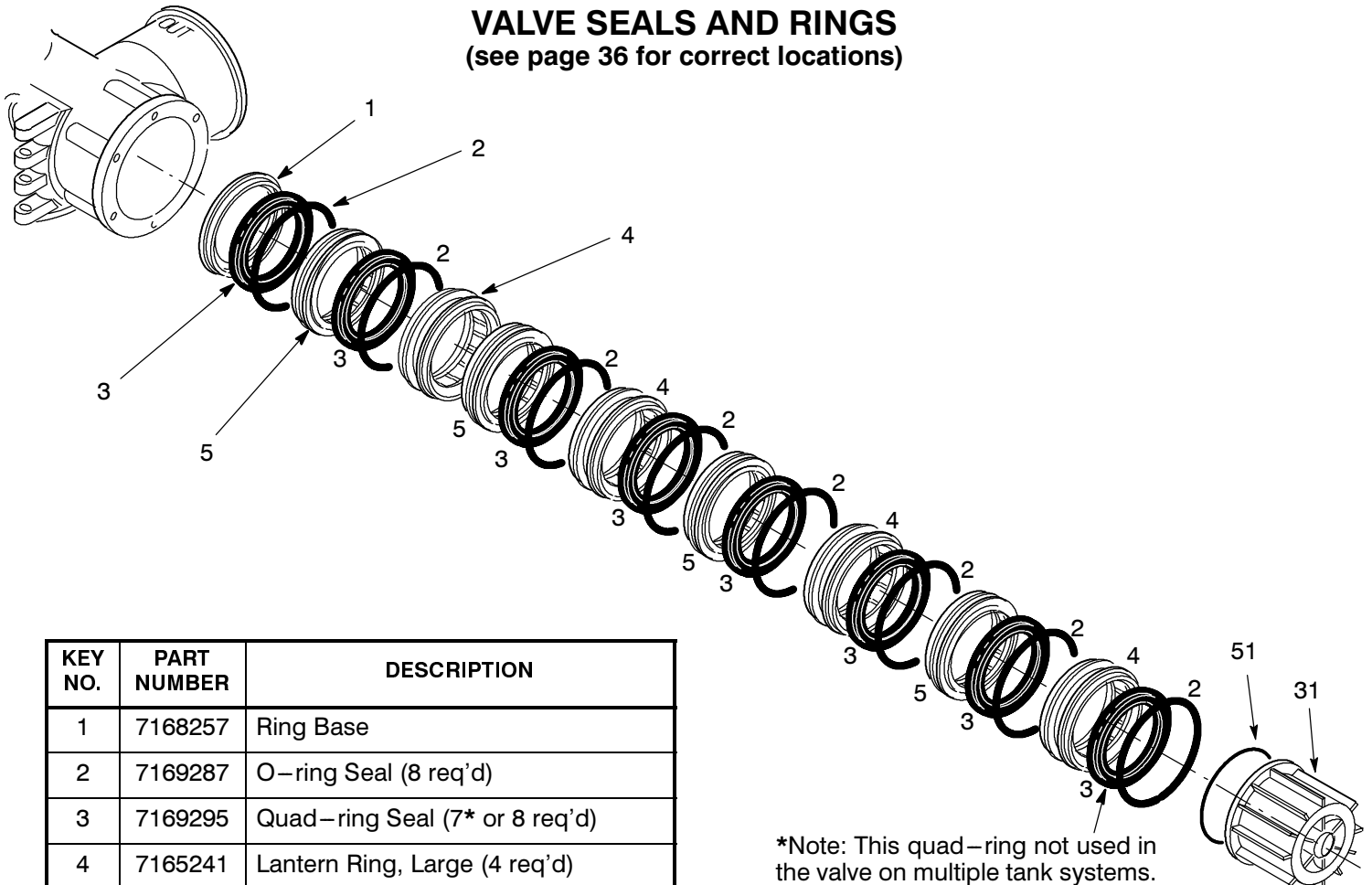

KEY NO.	PART NUMBER	DESCRIPTION
1	7168257	Ring Base
2	7169287	O-ring Seal (8 req'd)
3	7169295	Quad-ring Seal (7* or 8 req'd)
4	7165241	Lantern Ring, Large (4 req'd)
5	7165259	Lantern Ring, Small (4 req'd)
★	7195238	Seal Kit (8 each of key nos. 2 & 3)

*Note: This quad-ring not used in the valve on multiple tank systems.

DRIVE MECHANISM AND HOUSING

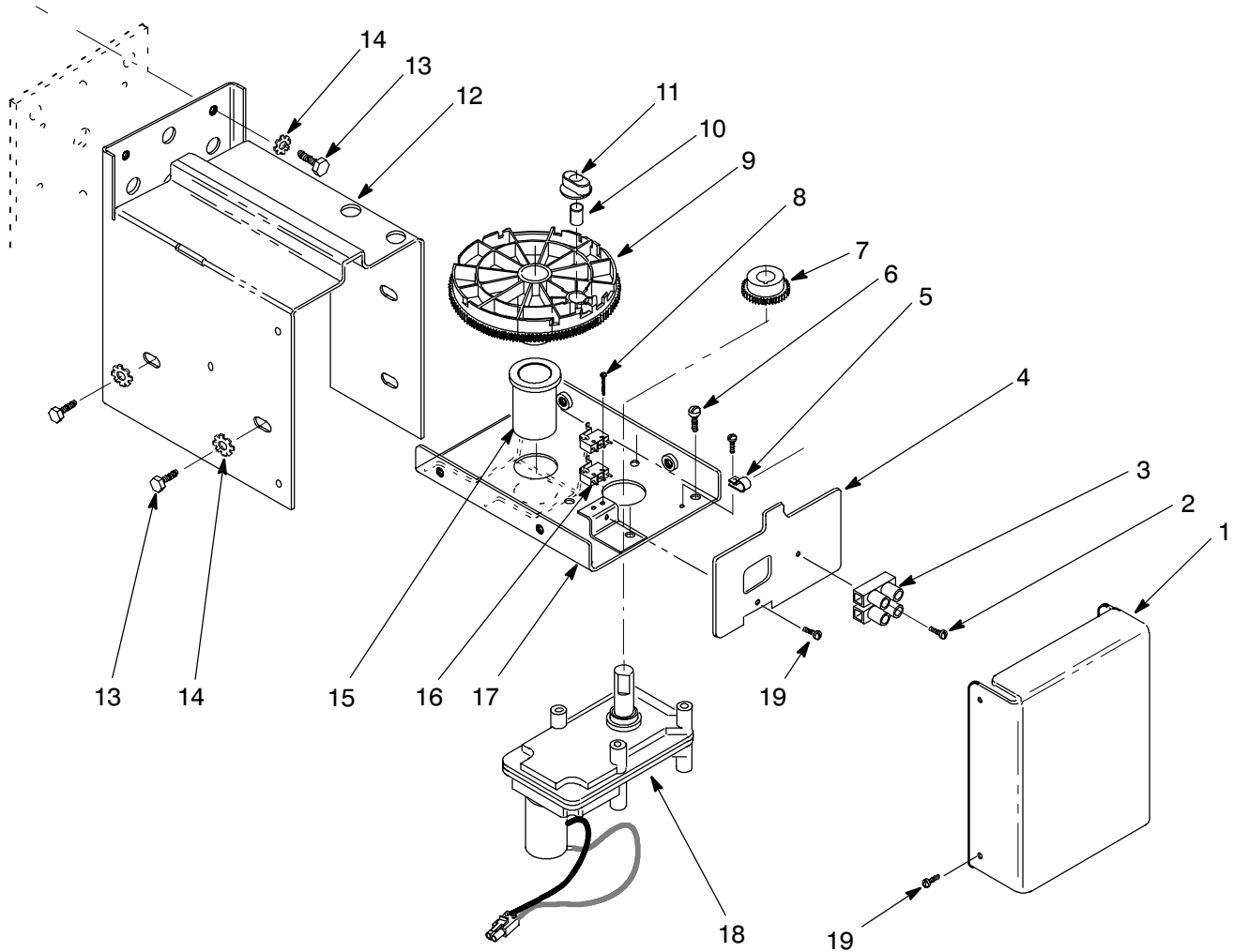

REPAIR PARTS LIST

KEY NO.	PART NUMBER	DESCRIPTION
1	7185233	Wire Cover
2	9006030	Screw, #6 – 20 x 5/8"
3	7176098	Base Flat Strip
4	7186344	Guard Plate
5	7187879	Strain Relief
6	7191349	Screw, #10 – 32 x 1/2" (3)
7	7169855	Pinion
8	7174004	Screw, #2 x 5/8" (2)
9	7172785	Cam & Gear (includes key no. 10)
10	7172913	Drive Pin

KEY NO.	PART NUMBER	DESCRIPTION
11	7169520	Slot Follower
12	7169423	Outer Bracket
13	0900296	Screw, 1/4" – 20 x 5/8" (8)
14	7151496	Lockwasher (8)
15	7169407	Flanged Bearing
16	7169863	Micro Switch (2)
17	7186336	Inner Bracket
–	7179177	Cam (Position) Decal
18	7169415	Motor
19	7190759	Screw, #6 – 32 x 3/8" (5)